

Compact Air Conditioners

1000-1800 BTU/Hr. (293-527 Watts)



M13



M17

Features

- Stock models are equipped with a thermostat control that offers convenient digital display of enclosure temperature and high temperature alarm (125°F/52°C). Flashing display indicates alarm condition. EMI/RFI noise suppressor and UL/CUL and CE are standard on stock models.
- Genesis™ units are directly interchangeable with the comparable Slimboy Series.
- Genesis™ M13 offers a unique passive condensate management system, which evaporates moisture from enclosure and eliminates drain tubes, buckets and wet floors in typical applications. Genesis™ M17 utilizes an active condensate management system that actively evaporates moisture from enclosure and eliminates drain tubes, buckets and wet floors in typical applications.
- Compact models are ideal for cooling smaller enclosures from 25 cu. ft. to 40 cu. ft. The ultra-narrow M17 Series is only 12" wide making it perfect for enclosures with narrow side walls.
- EZ Mount flanges simplify installation to a two-step, one-person job.
- High-performance, industrial-grade ball-bearing fans used to provide maximum heat transfer.
- Most components accessible by removing grille/filter.
- 100% functionally tested.
- Mounting hardware, gaskets, drawings, mounting template and instruction manual furnished.
- All units use a CFC-free or environmentally safe refrigerant.



TYPE 12 RoHS

UL TYPE 12 approval is standard on all stock models. UL/cUL listing available on most models. (UL File SA6453)

Other Units To Consider

Genesis™ M17: CR23, pg. B.3; CR23 Stainless Steel, pg. B.21

Option Packages (see pg. B.47)

	M13	M17
Thermostat Package	✓	✓
Thermostat/Malfunction Package	✓	✓
Special Voltage Package	✓	✓
Outdoor Package*	✓	✓
Harsh Environment Package*	✓	✓
Stainless Steel Package*	✓	✓

* Please refer to pages B.21-B.24 for our air conditioners that have been engineered and manufactured specifically for demanding applications.

McLean Thermal Closed-loop Cooling

Within the air conditioner, the recirculated clean enclosure air is kept separate from the ambient airflow system. This protects the electronic controls and prevents shutdowns caused by heat, humidity, dust and other contaminants.

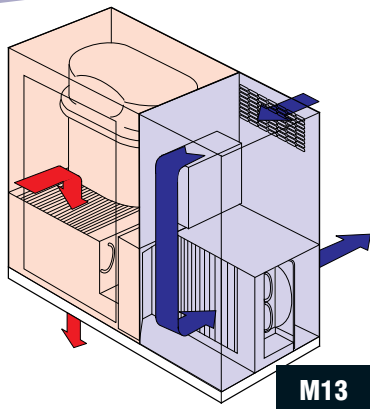

GENESIS™ M13 Series

1000 BTU/Hr. (293 Watts)
H x W x D: 13.25" (337) x 14.25" (362) x 7.80" (198)

Model		Voltage	Hz	Full Load Amps	Phase	BTU/Hr @ Max Amb Temp	Max Amb Temp °F/°C	Shipping Weight Lbs/Kgs
M13-0116-G1014	STOCK	115	50/60	4.0/4.0	1	800/1000	125/52	48/22
M13-0116-G1XXX		115	50/60	4.0/4.0	1	800/1000	125/52	48/22
M13-0126-G1008	STOCK	230	50/60	2.2/2.1	1	800/1000	125/52	48/22
M13-0126-G1XXX		230	50/60	2.2/2.1	1	800/1000	125/52	48/22
M13-0146-G1400		400/460	50/60	1.2/1.2	1	800/1000	125/52	58/26
M13-0146-G1XXX *		400/460	50/60	1.2/1.2	1	800/1000	125/52	58/26

* Transformer mounted outside in a separate box attached to the unit.

-XXX will be replaced with a three-digit number designating all desired options. Consult the factory for specific model numbers.

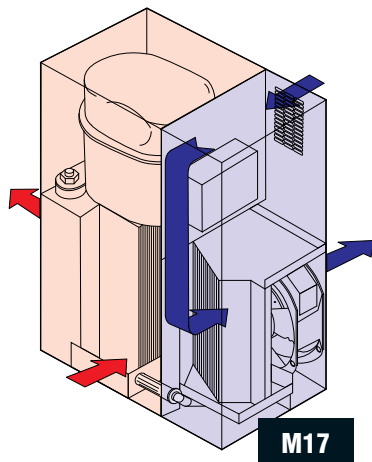

GENESIS™ M17 Series

1800 BTU/Hr. (527 Watts)
H x W x D: 17.65" (448) x 12" (305) x 8.68" (220)

Model		Voltage	Hz	Full Load Amps	Phase	BTU/Hr @ Max Amb Temp	Max Amb Temp °F/°C	Shipping Weight Lbs/Kgs
M17-0216-G009	STOCK	110/115	50/60	6.6/6.7	1	1500/1800	125/52	56/25
M17-0216-G0XX		110/115	50/60	6.6/6.7	1	1500/1800	125/52	56/25
M17-0226-G004	STOCK	220/230	50/60	4.2/3.7	1	1500/1800	125/52	56/25
M17-0226-G0XX		220/230	50/60	4.2/3.7	1	1500/1800	125/52	56/25
M17-0246-G004		440/460	50/60	2.3/2.0	1	1500/1800	125/52	66/30
M17-0246-GXXX *		440/460	50/60	2.3/2.0	1	1500/1800	125/52	66/30

* Transformer mounted outside in a separate box attached to the unit.

-XX will be replaced with a two-digit number designating all desired options. Consult the factory for specific model numbers.

- Ambient air flow
- Clean air flow

GENESIS™ M13 Series CUT-OUT NOTES

1. Dash lines represent air conditioner.
2. Cut-out dimensions for standard product only.
3. Full-size mounting template provided.

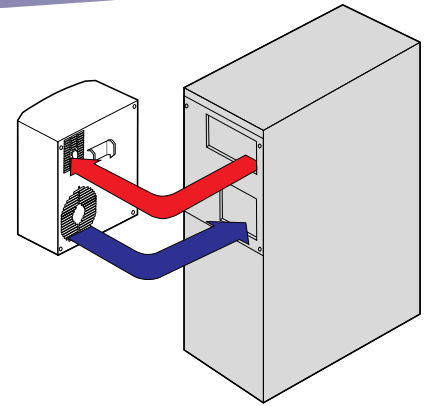
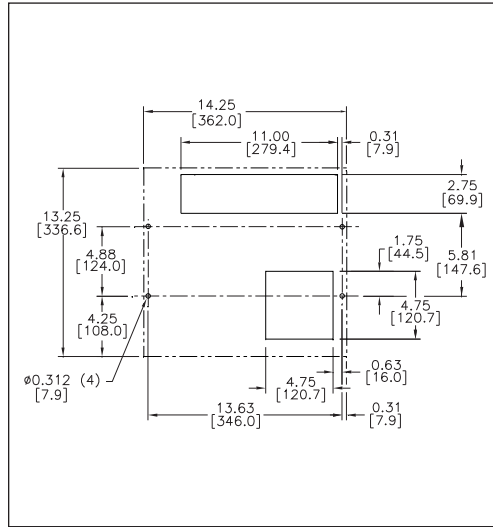

SIDE MOUNT TO ENCLOSURE

For TYPE 12 enclosure, interfacing air-out and air-in openings are required in the enclosure wall. Generally, the M13 Series is most effective on enclosures up to 25 cu. ft., unless the application is only for spot cooling in a larger enclosure.

GENESIS™ M17 Series CUT-OUT NOTES

1. Dash lines represent air conditioner.
2. Cut-out dimensions for standard product only.
3. Full-size mounting template provided.

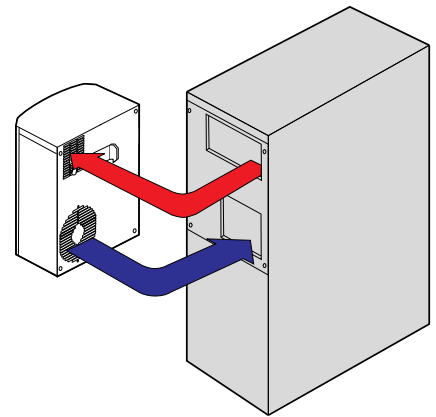
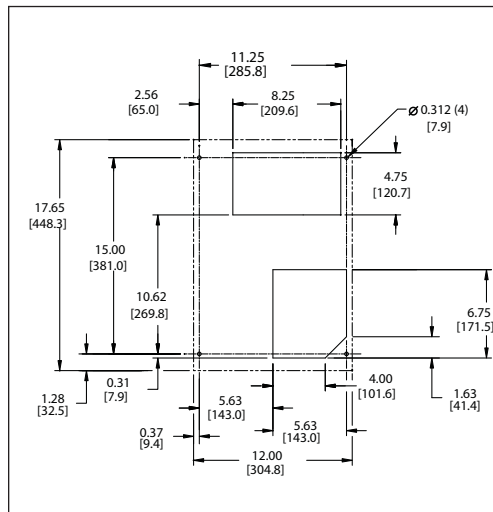

SIDE MOUNT TO ENCLOSURE

For TYPE 12 enclosure, interfacing air-out and air-in openings are required in the enclosure wall. Generally, the M17 Series is most effective on enclosures up to 40 cu. ft., unless the application is only for spot cooling in a larger enclosure.

DESIGN NOTES

1. Gasket kit for mounting to enclosure included.

2. Service cord.

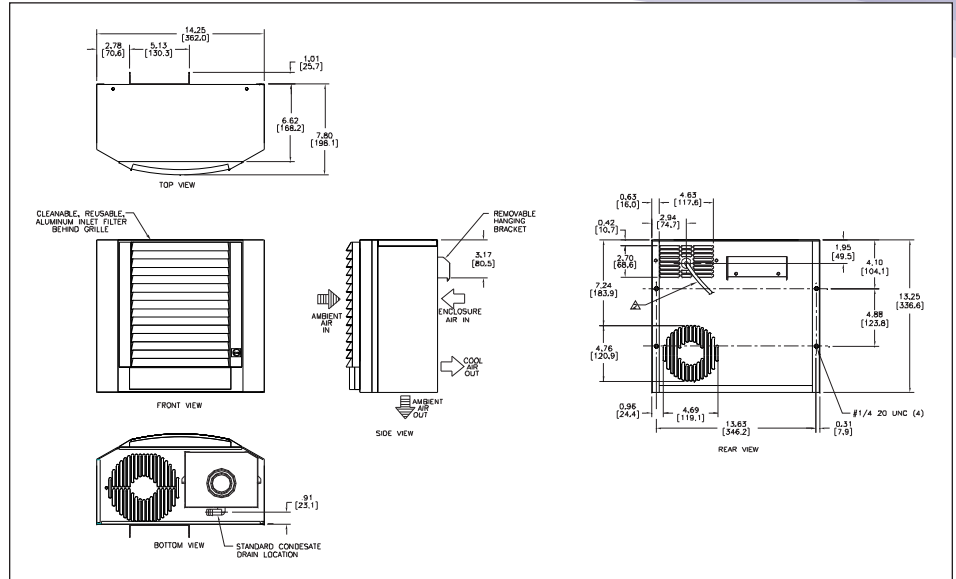

DESIGN NOTES

1. Gasket kit for mounting to enclosure included.

2. Service cord.

3. Condensate from enclosure drains to bottom pan of unit where it is evaporated by condenser heat.

