



---

---

*SERVO DRIVE*

---

---

# MicroFlex Servo Control

Installation Manual



---

# Contents

1	General Information	1-1
2	Introduction	2-1
2.1	MicroFlex features	2-1
2.2	Receiving and inspection	2-2
2.2.1	Identifying the catalog number	2-2
2.3	Units and abbreviations	2-3
3	Basic Installation	3-1
3.1	Introduction	3-1
3.1.1	Power sources	3-1
3.1.2	Hardware requirements	3-1
3.1.3	Tools and miscellaneous hardware	3-2
3.1.4	Other information needed for installation	3-2
3.2	Mechanical installation and cooling requirements	3-3
3.2.1	Dimensions	3-4
3.2.2	Mounting and cooling the MicroFlex	3-5
3.2.3	Derating characteristic - 3A model	3-6
3.2.4	Derating characteristic - 6A model	3-7
3.2.5	Derating characteristic - 9A model	3-8
3.2.6	Overtemperature trips	3-8
3.3	Connector locations	3-9
3.4	Power connections	3-10
3.4.1	Earthing / grounding	3-10
3.4.2	Single-phase or three-phase power connections	3-11
3.4.3	Input power conditioning	3-12
3.4.4	Power disconnect and protection devices	3-13
3.4.5	Recommended fuses and wire sizes	3-14
3.4.6	Drive overload protection	3-14
3.4.7	Power supply filters	3-15
3.4.8	24V control circuit supply	3-16
3.5	Motor connections	3-17
3.5.1	Motor circuit contactors	3-18
3.5.2	Motor power cable pin configuration - Baldor BSM rotary motors	3-18
3.5.3	Motor cable pin configuration - Baldor linear motors	3-19
3.6	Regeneration resistor (Dynamic Brake resistor)	3-20
4	Feedback	4-1
4.1	Introduction	4-1
4.1.1	Encoder feedback - X8	4-2
4.1.2	SSI feedback - X8	4-6
4.1.3	Encoder output - X7	4-8

<b>5</b>	<b>Input / Output</b>	<b>5-1</b>
5.1	Introduction	5-1
5.2	Analog I/O	5-2
5.2.1	Analog input - X3 (demand)	5-2
5.3	Digital I/O	5-4
5.3.1	Drive enable input - X3	5-5
5.3.2	General purpose digital input - X3	5-7
5.3.3	Step (pulse) and direction inputs - X3	5-9
5.3.4	Status output - X3	5-11
5.4	Serial port - X6	5-13
5.4.1	Using RS232 cable	5-13
5.4.2	Multidrop using RS485 / RS422 cable	5-14
5.4.3	Connecting serial Baldor HMI Operator Panels	5-15
5.5	Connection summary - recommended system wiring	5-16
<b>6</b>	<b>Configuration</b>	<b>6-1</b>
6.1	Introduction	6-1
6.1.1	Connecting the MicroFlex to the PC	6-1
6.1.2	Installing the software	6-1
6.1.3	Starting the MicroFlex	6-2
6.1.4	Preliminary checks	6-2
6.1.5	Power on checks	6-2
6.2	WorkBench v5	6-3
6.2.1	Help file	6-4
6.2.2	Starting WorkBench v5	6-5
6.2.3	Commissioning Wizard	6-7
6.2.4	Using the Commissioning Wizard	6-7
6.3	Further configuration	6-8
6.3.1	Fine-tuning tool	6-8
6.3.2	Parameters tool	6-10
6.3.3	Other tools and windows	6-11
<b>7</b>	<b>Troubleshooting</b>	<b>7-1</b>
7.1	Introduction	7-1
7.1.1	Problem diagnosis	7-1
7.1.2	SupportMe feature	7-1
7.1.3	Power-cycling the MicroFlex	7-1
7.2	Status LED	7-2
7.2.1	Communication	7-3
7.2.2	Power on	7-4
7.2.3	Tuning	7-4

<b>8</b>	<b>Specifications</b>	<b>8-1</b>
8.1	Introduction	8-1
8.1.1	AC input power and DC bus voltage (X1)	8-1
8.1.2	24VDC control circuit supply input (X2)	8-3
8.1.3	Motor output power (X1)	8-3
8.1.4	Regeneration (X1)	8-3
8.1.5	Analog input (X3)	8-4
8.1.6	Digital inputs - drive enable and general purpose (X3)	8-4
8.1.7	Step and Direction inputs (X3)	8-4
8.1.8	Drive status output (X3)	8-5
8.1.9	Incremental encoder feedback option (X8)	8-5
8.1.10	SSI encoder feedback option (X8)	8-5
8.1.11	Encoder output (simulated) (X7)	8-5
8.1.12	Serial RS232/RS485 interface (X6)	8-6
8.1.13	Environmental	8-6

## Appendices

<b>A</b>	<b>Accessories</b>	<b>A-1</b>
A.1	Introduction	A-1
A.1.1	Fan tray	A-2
A.1.2	EMC filters	A-3
A.1.3	Regeneration resistors	A-5
A.1.4	Motor power cables	A-6
A.1.5	Motor power cable part numbers	A-6
A.1.6	SSI feedback cables	A-7
A.1.7	Encoder / Hall feedback cables	A-8
A.1.8	Feedback cable part numbers	A-9
<b>B</b>	<b>Control System</b>	<b>B-1</b>
B.1	Introduction	B-1
B.1.1	Current (Torque) control	B-2
B.1.2	Velocity (Speed) control	B-3
B.1.3	Position (Step and Direction) control	B-4
<b>C</b>	<b>CE Guidelines</b>	<b>C-1</b>
C.1	Outline	C-1
C.1.1	EMC Conformity and CE marking	C-1
C.1.2	MicroFlex compliance	C-1
C.1.3	Declaration of conformity	C-2
C.1.4	Use of CE compliant components	C-3
C.1.5	EMC wiring technique	C-3
C.1.6	EMC installation suggestions	C-4
C.1.7	Wiring of shielded (screened) cables	C-5



---

Copyright Baldor (c) 2004. All rights reserved.

This manual is copyrighted and all rights are reserved. This document or attached software may not, in whole or in part, be copied or reproduced in any form without the prior written consent of Baldor. Baldor makes no representations or warranties with respect to the contents hereof and specifically disclaims any implied warranties of fitness for any particular purpose. The information in this document is subject to change without notice. Baldor assumes no responsibility for any errors that may appear in this document.

Mint™ is a registered trademark of Baldor.

Windows 95, Windows 98, Windows ME, Windows NT, Windows XP and Windows 2000 are registered trademarks of the Microsoft Corporation. UL and cUL are registered trademarks of Underwriters Laboratories.

#### Limited Warranty

For a period of two (2) years from the date of original purchase, Baldor will repair or replace without charge controls and accessories that our examination proves to be defective in material or workmanship. This warranty is valid if the unit has not been tampered with by unauthorized persons, misused, abused, or improperly installed and has been used in accordance with the instructions and/or ratings supplied. This warranty is in lieu of any other warranty or guarantee expressed or implied. Baldor shall not be held responsible for any expense (including installation and removal), inconvenience, or consequential damage, including injury to any person or property caused by items of our manufacture or sale. (Some countries and U.S. states do not allow exclusion or limitation of incidental or consequential damages, so the above exclusion may not apply.) In any event, Baldor's total liability, under all circumstances, shall not exceed the full purchase price of the control. Claims for purchase price refunds, repairs, or replacements must be referred to Baldor with all pertinent data as to the defect, the date purchased, the task performed by the control, and the problem encountered. No liability is assumed for expendable items such as fuses. Goods may be returned only with written notification including a Baldor Return Authorization Number and any return shipments must be prepaid.

## Product notice

Only qualified personnel should attempt the start-up procedure or troubleshoot this equipment. This equipment may be connected to other machines that have rotating parts or parts that are controlled by this equipment. Improper use can cause serious or fatal injury.

## Safety Notice

Intended use: These drives are intended for use in stationary ground based applications in industrial power installations according to the standards EN60204 and VDE0160. They are designed for machine applications that require variable speed controlled three-phase brushless AC motors. These drives are not intended for use in applications such as:

- Home appliances
- Medical instrumentation
- Mobile vehicles
- Ships
- Airplanes.

Unless otherwise specified, this drive is intended for installation in a suitable enclosure. The enclosure must protect the drive from exposure to excessive or corrosive moisture, dust and dirt or abnormal ambient temperatures. The exact operating specifications are found in section 8 of this manual. The installation, connection and control of drives is a skilled operation, disassembly or repair must not be attempted. In the event that a drive fails to operate correctly, contact the place of purchase for return instructions.

## Precautions



**DANGER:** Do not touch any circuit board, power device or electrical connection before you first ensure that no high voltage is present at this equipment or other equipment to which it is connected. Electrical shock can cause serious or fatal injury. Only qualified personnel should attempt to start-up, program or troubleshoot this equipment.



**DANGER:** The motor circuit might have high voltages present whenever AC power is applied, even when the motor is not moving. Electrical shock can cause serious or fatal injury.



**DANGER:** If a motor is driven mechanically, it might generate hazardous voltages that are conducted to its power terminals. The enclosure must be earthed/grounded to prevent possible shock hazard.



**DANGER:** Be sure the system is properly earthed/grounded before applying power. Do not apply AC power before you ensure that earths/grounds are connected. Electrical shock can cause serious or fatal injury.



**WARNING:** Be sure all wiring complies with the National Electrical Code and all regional and local codes. Improper wiring may result in unsafe conditions.



**WARNING:** Be sure that you are completely familiar with the safe operation and programming of this equipment. This equipment may be connected to other machines that have rotating parts or parts that are controlled by this equipment. Improper use can cause serious or fatal injury.



**WARNING:** The stop input to this equipment should not be used as the single means of achieving a safety critical stop. Drive disable, motor disconnect, motor brake and other means should be used as appropriate.



**WARNING:** Improper operation or programming of the drive may cause violent motion of the motor and driven equipment. Be certain that unexpected motor movement will not cause injury to personnel or damage to equipment. Peak torque of several times the rated motor torque can occur during control failure.



**WARNING:** When operating a rotary motor with no load coupled to its shaft, remove the shaft key to prevent it flying out when the shaft rotates.



**WARNING:** A regeneration resistor may generate enough heat to ignite combustible materials. To avoid fire hazard, keep all combustible materials and flammable vapors away from the brake resistors.



**CAUTION:** To prevent equipment damage, be certain that the input power has correctly sized protective devices installed.



**CAUTION:** To prevent equipment damage, be certain that input and output signals are powered and referenced correctly.



**CAUTION:** To ensure reliable performance of this equipment be certain that all signals to/from the drive are shielded correctly.



**CAUTION:** Suitable for use on a circuit capable of delivering not more than the RMS symmetrical short circuit amperes listed here at rated voltage.

<u>Horsepower</u>	<u>RMS Symmetrical Amperes</u>
1-50	5,000



**CAUTION:** Avoid locating the drive immediately above or beside heat generating equipment, or directly below water or steam pipes.



**CAUTION:** Avoid locating the drive in the vicinity of corrosive substances or vapors, metal particles and dust.



**CAUTION:** Do not connect AC power to the drive terminals U, V and W. Connecting AC power to these terminals may result in damage to the drive.



**CAUTION:** Baldor does not recommend using "Grounded Leg Delta" transformer power leads that may create earth/ground loops and degrade system performance. Instead, we recommend using a four wire Wye.



**CAUTION:** Drives are intended to be connected to a permanent main power source, not a portable power source. Suitable fusing and circuit protection devices are required.



**CAUTION:** The safe integration of the drive into a machine system is the responsibility of the machine designer. Be sure to comply with the local safety requirements at the place where the machine is to be used. In Europe these are the Machinery Directive, the ElectroMagnetic Compatibility Directive and the Low Voltage Directive. In the United States this is the National Electrical code and local codes.



**CAUTION:** Drives must be installed inside an electrical cabinet that provides environmental control and protection. Installation information for the drive is provided in this manual. Motors and controlling devices that connect to the drive should have specifications compatible to the drive.



**CAUTION:** Failure to meet cooling air flow requirements will result in reduced product lifetime and/or drive overtemperature trips.



**CAUTION:** Violent jamming (stopping) of the motor during operation may damage the motor and drive.



**CAUTION:** Operating the MicroFlex in Torque mode with no load attached to the motor can cause the motor to accelerate rapidly to excessive speed.



**CAUTION:** If the drive enable signal is already present when power is applied to the MicroFlex, the motor could begin to move immediately.



**CAUTION:** Do not tin (solder) exposed wires. Solder contracts over time and may cause loose connections. Use crimp connections where possible.



**CAUTION:** Electrical components can be damaged by static electricity. Use ESD (electrostatic discharge) procedures when handling this drive.



**CAUTION:** Ensure that encoder wires are properly connected. Incorrect installation may result in improper movement.



**CAUTION:** The threaded holes in the top and bottom of the case are for cable clamps. The holes are 11.5 mm deep and accept M4 screws, which must be screwed in to a depth of at least 8mm.



**CAUTION:** Removing the cover will invalidate UL certification.



**CAUTION:** The metal heatsink on the left side of the MicroFlex can become very hot during normal operation.

## 2.1 MicroFlex features

The MicroFlex is a versatile brushless servo drive, providing a flexible and powerful motion control solution for rotary and linear motors. Standard features include:

- Single axis AC brushless drive.
- Range of models with continuous current ratings of 3A, 6A or 9A.
- Direct connection to 115VAC or 230VAC single-phase or 230VAC three-phase supplies.
- SSI or incremental encoder feedback.
- Velocity and current control, with step and direction input for position control.
- Auto-tuning wizard (including position loop) and software oscilloscope facilities provided by WorkBench v5 configuration software (supplied).
- 2 optically isolated digital inputs (one enable input and one general purpose input).
- 1 optically isolated digital output to indicate error conditions.
- 1 general-purpose analog input (can be used as a speed or torque command reference).
- RS232 or RS485 communications (model dependent) for setup and diagnostics.

MicroFlex will operate with a large range of brushless rotary and linear servo motors - for information on selecting Baldor servo motors, please see the sales brochure BR1202 available from your local Baldor representative.

This manual is intended to guide you through the installation of MicroFlex. The sections should be read in sequence.

The *Basic Installation* section describes the mechanical installation of the MicroFlex, the power supply connections and motor connections. The other sections require knowledge of the low level input/output requirements of the installation and an understanding of computer software installation. If you are not qualified in these areas you should seek assistance before proceeding.

## 2.2 Receiving and inspection

When you receive your MicroFlex, there are several things you should do immediately:

1. Check the condition of the shipping container and report any damage immediately to the carrier that delivered your MicroFlex.
2. Remove the MicroFlex from the shipping container and remove all packing material. The container and packing materials may be retained for future shipment.
3. Verify that the catalog number of the MicroFlex you received is the same as the catalog number listed on your purchase order. The catalog number is described in the next section.
4. Inspect the MicroFlex for external damage during shipment and report any damage to the carrier that delivered your MicroFlex.
5. If MicroFlex is to be stored for several weeks before use, be sure that it is stored in a location that conforms to the storage humidity and temperature specifications shown in section 8.1.13.

### 2.2.1 Identifying the catalog number

The MicroFlex is available with different current ratings. The catalog number is marked on the side of the unit. It is a good idea to look for the catalog number (sometimes shown as ID/No: ) and write it in the space provided here:

**Catalog number:** **FMH** \_\_\_\_\_ - \_\_\_\_\_

**Installed at:** \_\_\_\_\_

**Date:** \_\_\_\_\_

A description of a catalog number is shown here, using the example **FMH2A03TR-EN23**:

	Meaning	Alternatives
<b>FMH</b>	MicroFlex family	-
<b>2</b>	Requires an AC supply voltage of 115-230 Volts, 1Φ or 3Φ	-
<b>A03</b>	Continuous current rating of 3A	<b>A06=6A; A09=9A</b>
<b>T</b>	Built in AC power supply	-
<b>R</b>	Requires external braking resistor	-
<b>E</b>	Supported feedback types are encoder or SSI	-
<b>N</b>	No options specified	-
<b>2</b>	Serial port type is RS232	<b>4 = RS485</b>
<b>3</b>	24VDC supply is required to power the control logic	-

## 2.3 Units and abbreviations

The following units and abbreviations may appear in this manual:

A	.....	Ampere
AC	.....	Alternating current
DC	.....	Direct current
dB	.....	decibel
kW	.....	kilowatt
mA	.....	milliampere
mH	.....	millihenry
mΩ	.....	milliohm
pF	.....	picofarad
V	.....	Volt (also VAC and VDC)
W	.....	Watt
μA	.....	microampere
μH	.....	microhenry
μF	.....	microfarad
Ω	.....	Ohm

Hz	.....	hertz
kHz	.....	kilohertz
MHz	.....	megahertz
ms	.....	millisecond
ns	.....	nanosecond
s	.....	second
μs	.....	microsecond
Φ	.....	phase

CD	.....	Compact Disc
CTRL+E	.....	on the PC keyboard, press <b>Ctrl</b> then <b>E</b> at the same time.
Kbaud	.....	kilobaud (the same as Kbit/s in most applications)
MB	.....	megabytes

ft	.....	feet
ft/s	.....	feet per second
in	.....	inch
lb-in	.....	pound-inch (torque)
mm	.....	millimeter
m	.....	meter
m/s	.....	meters per second
Nm	.....	Newton-meter (torque)

ADC	.....	Analog to Digital Converter
AWG	.....	American Wire Gauge
DAC	.....	Digital to Analog Converter
SSI	.....	Synchronous Serial Interface
(NC)	.....	Not Connected



## 3.1 Introduction

**You should read all the sections in *Basic Installation* to ensure safe installation.**

This section describes the mechanical and electrical installation of the MicroFlex in the following stages:

- Location considerations
- Mounting the MicroFlex
- Connecting the AC power supply
- Connecting the 24VDC control circuit supply
- Connecting the motor
- Installing a regeneration resistor (Dynamic Brake)
- Connecting the feedback device

**These stages should be read and followed in sequence.**

### 3.1.1 Power sources

A 115 - 230VAC power source (IEC1010 over-voltage category III or less) in the installation area is required. This may be single-phase or three-phase. An AC power filter is required to comply with the CE directive for which the MicroFlex was tested (see section 3.4.7).

The 24VDC control circuit supply must be a regulated power supply with a continuous current supply capability of 1A (4A power on surge).

### 3.1.2 Hardware requirements

The components you will need to complete the basic installation are:

- The motor that will be connected to the MicroFlex.
- A motor power cable.
- An encoder feedback cable (and Hall cable for linear motors).
- A serial cable connected as shown in section 5.4.
- (Optional) A regeneration resistor (Dynamic Brake) might be required, depending on the application. Without the regeneration resistor, the drive may produce an overvoltage fault. All MicroFlex models have overvoltage sensing circuitry. Regeneration resistors may be purchased separately - see Appendix A.
- A cooling fan may be required to allow operation of the MicroFlex at full rated current (see section 3.2.2).

- A PC with the following specification:

	Minimum specification	Recommended specification
<b>Processor</b>	Intel Pentium 133MHz	Intel Pentium 200MHz or faster
<b>RAM</b>	32MB	64MB
<b>Hard disk space</b>	40MB	60MB
<b>CD-ROM</b>	A CD-ROM drive	
<b>Serial port</b>	RS232 or RS485 serial port (depending on MicroFlex model)	
<b>Screen</b>	800 x 600, 256 colors	1024 x 768, 256 colors
<b>Mouse</b>	A mouse or similar pointing device	
<b>Operating system</b>	Windows 95, Windows 98, Windows ME, Windows NT, Windows XP or Windows 2000	

### 3.1.3 Tools and miscellaneous hardware

- Your PC operating system user manual might be useful if you are not familiar with Windows
- Small screwdriver(s) with a blade width of 3mm or less for connector X1, and 2.5mm (1/10 in) or less for connector X3.
- M5 screws or bolts for mounting the MicroFlex
- Crimping tool.

### 3.1.4 Other information needed for installation

This information is useful (but not essential) to complete the installation:

- The data sheet or manual provided with your motor, describing the wiring information of the motor cables/connectors
- Knowledge of whether the digital input signal will be 'Active Low' or 'Active High'.

## 3.2 Mechanical installation and cooling requirements

**It is essential that you read and understand this section before beginning the installation.**



**CAUTION:** To prevent equipment damage, be certain that the input power has correctly rated protective devices installed.



**CAUTION:** To prevent equipment damage, be certain that input and output signals are powered and referenced correctly.



**CAUTION:** To ensure reliable performance of this equipment be certain that all signals to/from the MicroFlex are shielded correctly.



**CAUTION:** Avoid locating the MicroFlex immediately above or beside heat generating equipment, or directly below water steam pipes.



**CAUTION:** Avoid locating the MicroFlex in the vicinity of corrosive substances or vapors, metal particles and dust.



**CAUTION:** Failure to meet cooling air flow requirements will result in reduced product lifetime and/or drive overtemperature trips.

The safe operation of this equipment depends upon its use in the appropriate environment. The following points must be considered:

- The MicroFlex must be installed indoors, permanently fixed and located so that it can only be accessed by service personnel using tools.
- The maximum suggested operating altitude is 1000m (3300ft).
- The MicroFlex must be installed where the pollution degree according to IEC664 shall not exceed 2.
- The 24VDC control circuit supply must be installed so that the 24VDC supplied to the unit is isolated from the AC supply using double or reinforced insulation.
- The input of the control circuit must be limited to Safety Extra Low Voltage circuits.
- Both the AC supply and the 24VDC supply must be fused.
- The atmosphere must not contain flammable gases or vapors.
- There must not be abnormal levels of nuclear radiation or X-rays.
- To comply with CE directive 89/336/EEC an appropriate AC filter must be installed.
- The MicroFlex must be secured by the slots in the flange. The protective earth/ground (the threaded hole on the top of the MicroFlex) must be bonded to a safety earth/ground using either a 25A conductor or a conductor of three times the peak current rating - whichever is the greater.
- The threaded holes in the top and bottom of the case are for cable clamps. The holes are threaded for M4 bolts no longer than 11mm (0.43 in) in length.
- Each D-type connector on the front panel of the MicroFlex is secured using two hexagonal jack screws (sometimes known as "screwlocks"). If a jack screw is removed accidentally or lost it must be replaced with a jack screw with an external male threaded section no longer than 10mm (0.4 in).

### 3.2.1 Dimensions

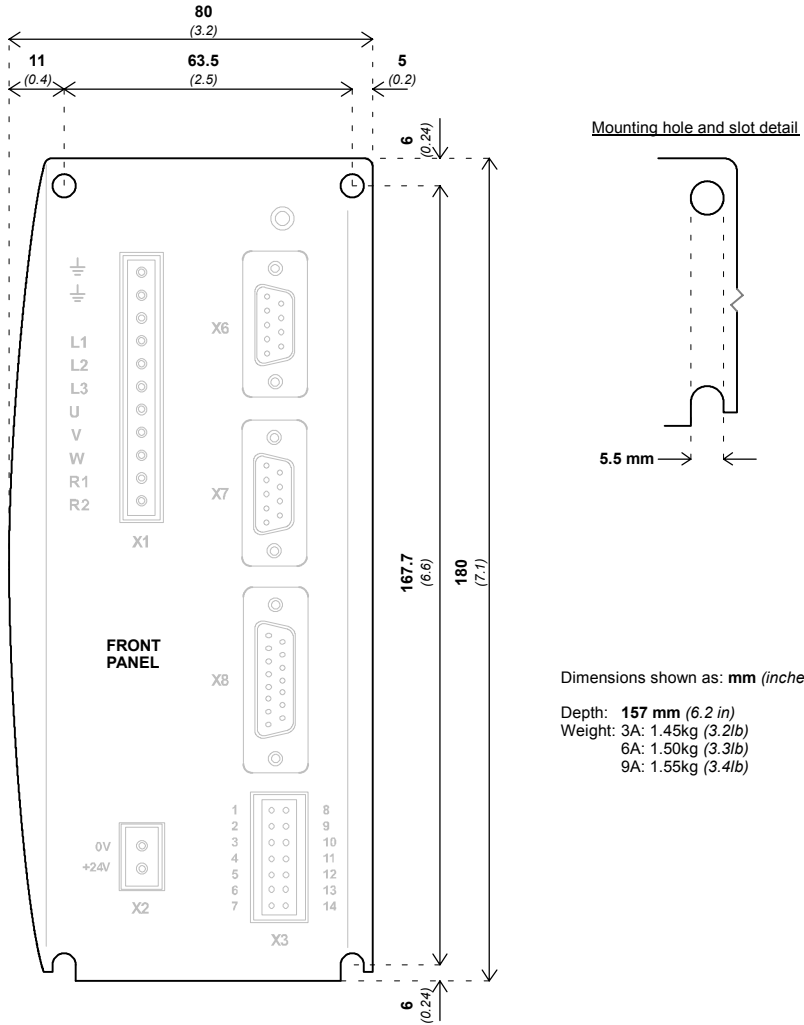

Figure 1 - Package dimensions

### 3.2.2 Mounting and cooling the MicroFlex

Ensure you have read and understood the *Mechanical installation and location requirements* in section 3.2. Mount the MicroFlex vertically on its rear side, the side opposite the front panel. M5 bolts or screws should be used to mount the MicroFlex. Detailed dimensions are shown in section 3.2.1.

For effective cooling, the MicroFlex must be mounted upright on a smooth vertical metal surface. The MicroFlex is designed to operate in an ambient temperature of 0°C to 45°C (32°F to 113°F). Output current must be derated between 45°C (113°F) and the absolute maximum ambient temperature of 55°C (131°F). Within the ambient temperature range:

The 3A model is designed to operate without any additional cooling methods. The 6A and 9A models require a forced air flow, passing vertically from the bottom to the top of the MicroFlex case, to allow full rated current at 45°C (113°F).

Temperature derating characteristics are shown in sections 3.2.3 to 3.2.5.

**Note:** Failure to meet cooling air flow requirements will result in reduced product lifetime and/or drive overtemperature trips. It is recommended to check periodically the operation of the cooling equipment.

#### 3.2.2.1 Effects of mounting surface and proximity

The proximity of the MicroFlex to other components could affect cooling efficiency. If the MicroFlex is mounted beside another MicroFlex (or other obstruction), there should be a minimum space of 15mm to maintain effective cooling.

If the MicroFlex is mounted above or below another MicroFlex (or other obstruction), there should be a minimum space of 90mm to maintain effective cooling. Remember that when a MicroFlex is mounted above another MicroFlex or heat source, it will be receiving air that has been already heated by the device(s) below it. Multiple MicroFlex units mounted above each other should be aligned, not offset, to promote air flow across the heatsinks.

The derating characteristics assume the MicroFlex is mounted on 3mm thick (or less) metal plate. If the MicroFlex is mounted on 10mm plate then the current characteristics shown in sections 3.2.3 to 3.2.5 may be increased by up to 7% if there is no forced air cooling, or 15% if forced air cooling is present.

It is recommended to allow approximately 60mm at the front to accommodate wiring and connectors.

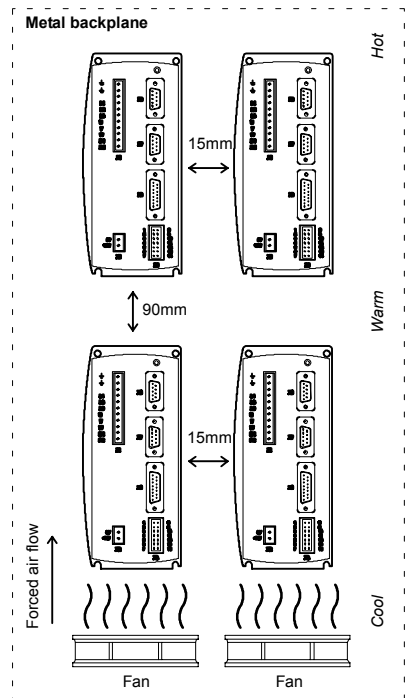
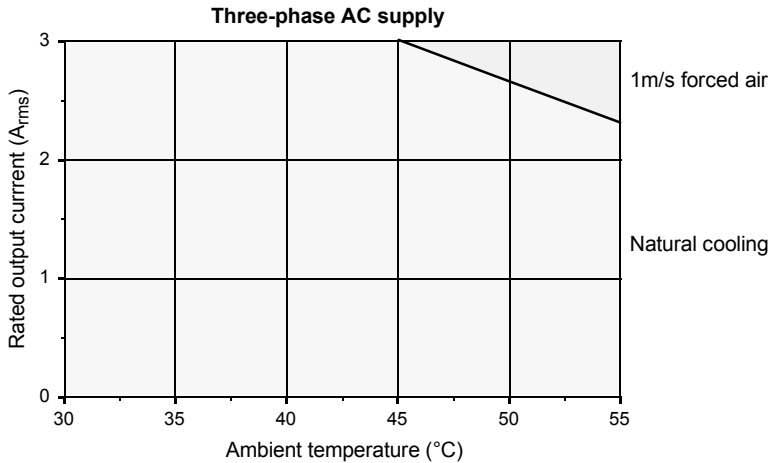
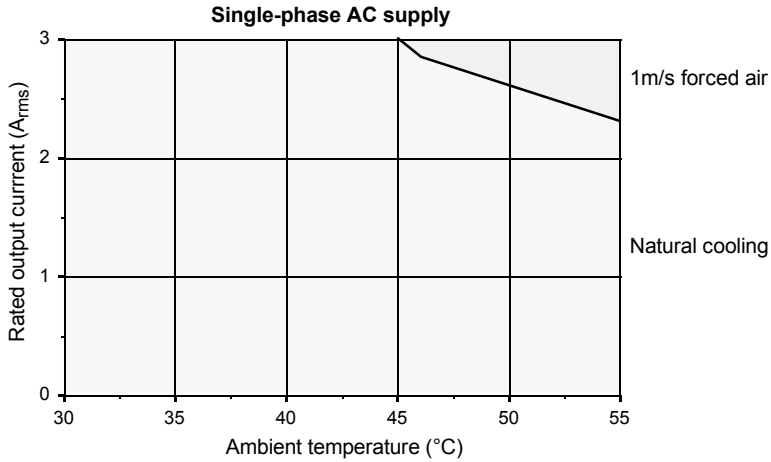

Figure 2 - Cooling and proximity

### 3.2.3 Derating characteristic - 3A model

The following derating characteristics are for model FMH2A03TR-EN23.



**Notes:**

Load power factor = 0.75.

Overload limit for model FMH2A03TR-EN23 is 6A.

### 3.2.4 Derating characteristic - 6A model

The following derating characteristics are for model FMH2A06TR-EN23.

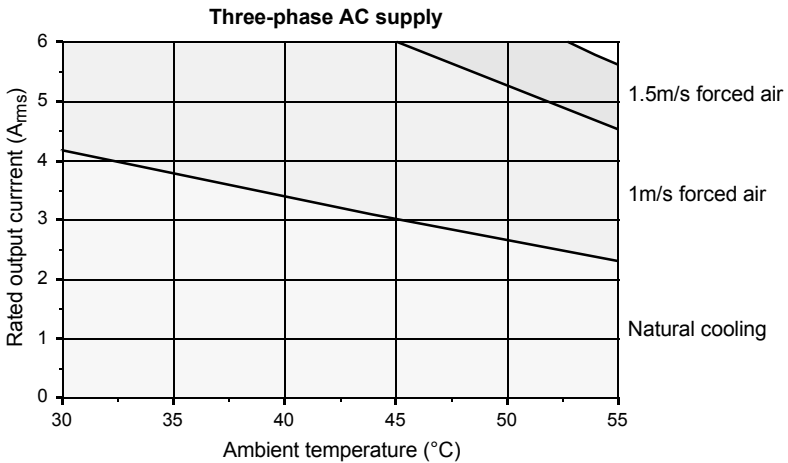
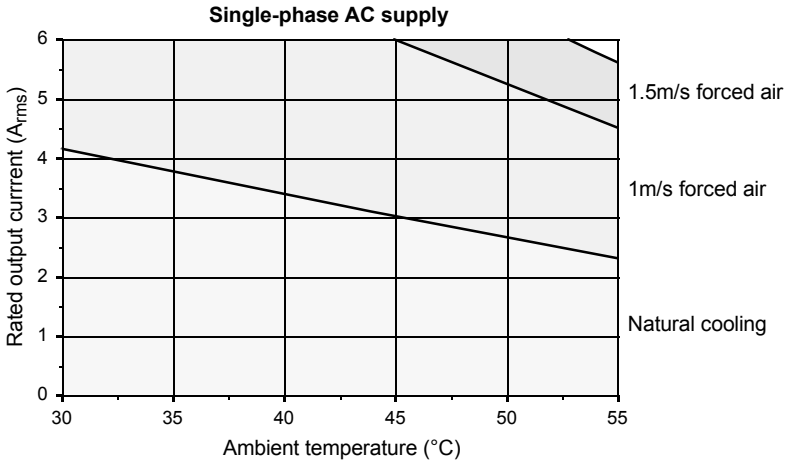

**Notes:**

Load power factor = 0.75.

Overload limit for model FMH2A06TR-EN23 is 12A.

### 3.2.5 Derating characteristic - 9A model

The following derating characteristics are for model FMH2A09TR-EN23.

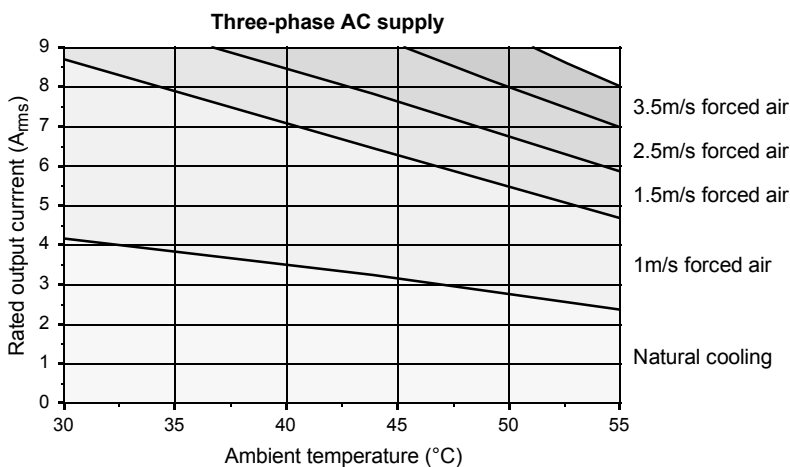
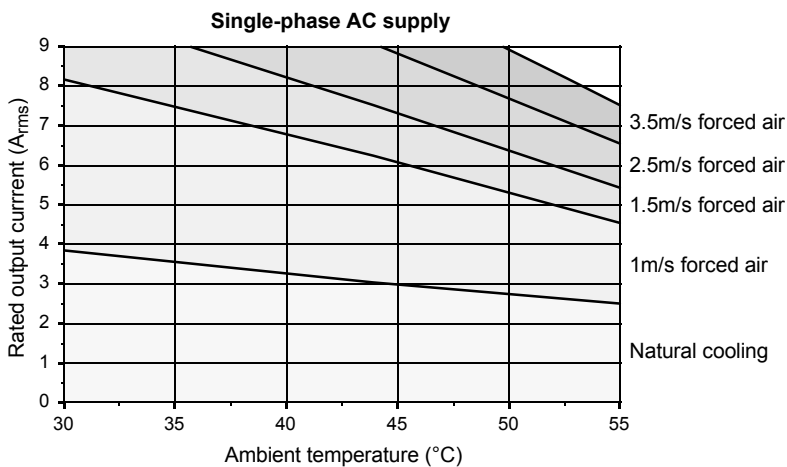

**Notes:**

Load power factor = 0.78.

Overload limit for model FMH2A09TR-EN23 is 18A.

### 3.2.6 Overtemperature trips

The MicroFlex contains internal temperature sensors that will cause it to trip and disable if the temperature exceeds 80°C on the 3A model, or 75°C on the 6A and 9A models. This limit can be read using the TEMPERATURELIMIT FATAL keyword - see the Mint help file for details.

### 3.3 Connector locations

#### X1 Power



- ⊕ Earth/Ground
- ⊖ Earth/Ground (NC)
- L1 AC Phase 1 / L
- L2 AC Phase 2 / N
- L3 AC Phase 3
- U Motor U
- V Motor V
- W Motor W
- R1 Regen
- R2 Regen

(NC) = Not Connected. Do not make a connection to this pin.

Tightening torque for terminal block connections is 0.5-0.6Nm (4.4-5.3 lb-in)

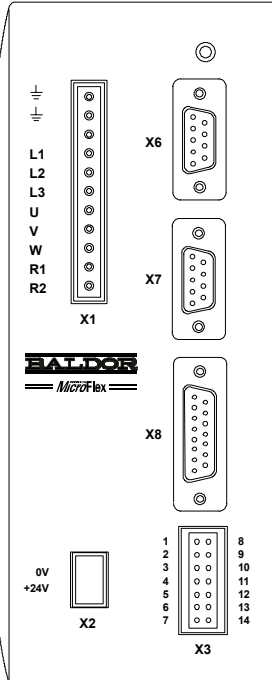

#### X2 Control circuit



- 0V
- +24V

#### X3 Input / Output



- |                 |          |
|-----------------|----------|
| 1 Shield        | 8 Shield |
| 2 Status-       | 9 Dir    |
| 3 Status+       | 10 Step  |
| 4 DINO-         | 11 DGND  |
| 5 DINO+         | 12 AINO- |
| 6 Drive enable- | 13 AINO+ |
| 7 Drive enable+ | 14 AGND  |

#### X6 RS232



- | RS232                    | RS485/422 |
|--------------------------|-----------|
| 1 (NC)                   | (NC)      |
| 2 RXD                    | RX-       |
| 3 TXD                    | TX-       |
| 4 (NC)                   | (NC)      |
| 5 0V GND                 | 0V GND    |
| 6 (NC)                   | (NC)      |
| 7 RTS                    | TX+       |
| 8 CTS                    | RX+       |
| 9 (NC - see section 5.4) | (NC)      |

#### X7 Encoder Out



- 1 CHA+
- 2 CHB+
- 3 CHZ+
- 4 (NC)
- 5 DGND
- 6 CHA-
- 7 CHB-
- 8 CHZ-
- 9 (NC)

#### X8 Feedback In



- | Incremental | SSI     |
|-------------|---------|
| 1 CHA+      | Data+   |
| 2 CHB+      | Clock+  |
| 3 CHZ+      | (NC)    |
| 4 Sense     | Sense   |
| 5 Hall U-   | (NC)    |
| 6 Hall U+   | (NC)    |
| 7 Hall V-   | (NC)    |
| 8 Hall V+   | (NC)    |
| 9 CHA-      | Data-   |
| 10 CHB-     | Clock-  |
| 11 CHZ-     | (NC)    |
| 12 +5V out  | +5V out |
| 13 DGND     | DGND    |
| 14 Hall W-  | (NC)    |
| 15 Hall W+  | (NC)    |

## 3.4 Power connections

This section provides instructions for connecting the AC power supply.

The installer of this equipment is responsible for complying with NEC (National Electric Code) guidelines or CE (Conformite Europeene) directives and application codes that govern wiring protection, earthing/grounding, disconnects and other current protection.



**DANGER:** Electrical shock can cause serious or fatal injury. Do not touch any power device or electrical connection before you first ensure that power has been disconnected and there is no high voltage present from this equipment or other equipment to which it is connected.

MicroFlex drives are designed to be powered from standard single and three-phase lines that are electrically symmetrical with respect to earth/ground. The power supply module within all MicroFlex models provides rectification, smoothing and current surge protection. Fuses or circuit breakers are required in the input lines for cable protection.

**Note:** A Residual Current Device (RCD) must not be used for fusing the drive. An appropriate type of circuit breaker or fuse must be used.

All interconnection wires should be in metal conduits between the MicroFlex, AC power source, motor, host controller and any operator interface stations. Use UL listed closed loop connectors that are of appropriate size for the wire gauge being used. Connectors are to be installed using only the crimp tool specified by the manufacturer of the connector. Only class 1 wiring should be used.

### 3.4.1 Earthing / grounding

A permanent earth/ground bonding point is provided on the heatsink, which must be used as the protective earth. It is labelled with the protective earth symbol in the casting and does not form any other mechanical function.

Connector X1 contains earth terminals, but these must not be used as protective earth since the connector does not guarantee earth connection first, disconnection last. Earthing methods are shown in section 3.4.2.

**Note:** When using unearthed/ungrounded distribution systems, an isolation transformer with an earthed/grounded secondary is recommended. This provides three-phase AC power that is symmetrical with respect to earth/ground and can prevent equipment damage.

#### 3.4.1.1 Protection class

User protection has been achieved using Protective Class I (EN61800-5-1, 3.2.20), which requires an earth connection to the unit whenever hazardous voltages are applied. The equipment provides protection against electric shock by:

- Means of connection of protective earth to accessible live conductive parts.
- Basic insulation.

#### 3.4.1.2 Earth leakage

Maximum earth leakage from the MicroFlex is 3.4mA per phase (230V 50Hz supply). This value does not include the earth leakage from the AC power filter, which could be much larger (see section A.1.2). If the MicroFlex and filter are mounted in an enclosure, it is recommended the enclosure is earthed using a 10mm<sup>2</sup> conductor.

### 3.4.2 Single-phase or three-phase power connections

<b>Location</b>	Connector X1 (Mating connector: Phoenix COMBICON MSTB 2,5HC/11-ST-5,08)
<b>Nominal input voltage</b>	115VAC or 230VAC, 1 $\Phi$ or 3 $\Phi$ line to line
<b>Minimum input voltage</b>	105VAC, 1 $\Phi$ or 3 $\Phi$ line to line (see Note*)
<b>Maximum input voltage</b>	250VAC, 1 $\Phi$ or 3 $\Phi$ line to line

**Note:** \* The MicroFlex will operate at lower input voltages, although performance could be impaired. The drive will trip if the DC-bus voltage falls below 50V or 60% of the no-load voltage, whichever occurs first.

For three phase supplies, connect supply to L1, L2 and L3 as shown in Figure 3. For single phase supplies, connect the supply between any two line inputs, for example L1 and L2.

For CE compliance, an AC filter must be connected between the AC power supply and the MicroFlex. If local codes do not specify different regulations, use at least the same gauge wire for earth/ground as is used for L1, L2 and L3.

Tightening torque for terminal block connections is 0.5-0.6Nm (4.4-5.3 lb-in). The threaded hole in the top and bottom of the case may be used as an additional functional earth/ground connection for signals on connector X3. They may also be used to attach shield or strain relief clamps. The holes are threaded for M4 bolts no longer than 11mm (0.43 in) in length.

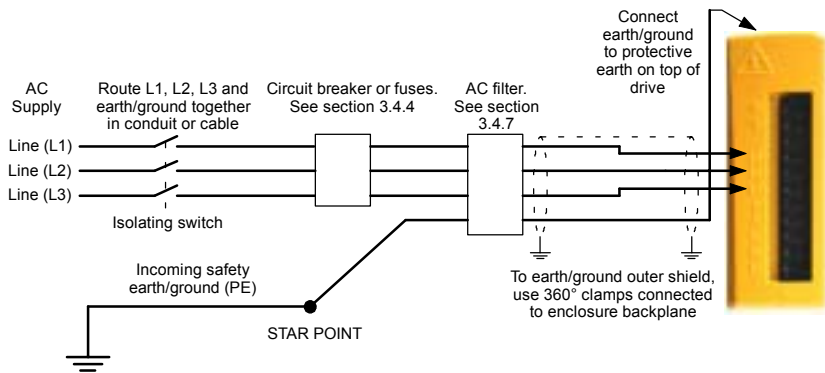

Figure 3 - Single or three-phase power connections

### 3.4.3 Input power conditioning

Certain power line conditions must be avoided; an AC line reactor, an isolation transformer or a step up/step down transformer may be required for some power conditions:

- If the feeder or branch circuit that provides power to the MicroFlex has permanently connected power factor correction capacitors, an input AC line reactor or an isolation transformer must be connected between the power factor correction capacitors and the MicroFlex.
- If the feeder or branch circuit that provides power to the MicroFlex has power factor correction capacitors that are switched on line and off line, the capacitors must not be switched while the drive is connected to the AC power line. If the capacitors are switched on line while the drive is still connected to the AC power line, additional protection is required. A Transient Voltage Surge Suppressor (TVSS) of the proper rating must be installed between the AC line reactor (or isolation transformer) and the AC input to the MicroFlex.

#### 3.4.3.1 Input power-cycling and inrush

If AC power has been removed from the MicroFlex, it should remain disconnected for the period specified in Table 1, before it is reapplied.

MicroFlex current rating	Minimum power cycle delay period (seconds)
3A	25
6A	45
9A	65

**Table 1 - Power cycle intervals**

This delay allows the input surge protection circuit to perform correctly, ensuring that the inrush current (typically 1.7A) is below the drive rated current. Power-cycling the drive more frequently could cause high inrush current and corresponding nuisance operation of circuit breakers or fuses. Repeated failure to observe the delay period could reduce the lifetime of the MicroFlex.

#### 3.4.3.2 Discharge period



**DANGER:** After AC power has been removed from the MicroFlex, high voltages (greater than 50VDC) will remain on the regeneration resistor connections until the DC-bus circuitry has discharged. The high voltage will remain for the period specified in Table 2.

MicroFlex current rating	Time for DC-bus to discharge to 50V or less (maximum, seconds)
3A	83
6A	166
9A	248

**Table 2 - DC-bus discharge periods**

### 3.4.4 Power disconnect and protection devices

A power disconnect should be installed between the input power supply and the MicroFlex for a fail-safe method to disconnect power. The MicroFlex will remain in a powered condition until all input power is removed from the drive and the internal bus voltage has depleted.

The MicroFlex must have a suitable input power protection device installed. Recommended circuit breakers are thermal magnetic devices (1 or 3 phase as required) with characteristics suitable for heavy inductive loads (D-type trip characteristic). Recommended fuses are shown in section 3.4.5. Circuit breaker or fuses are not supplied. For CE compliance, see Appendix C.

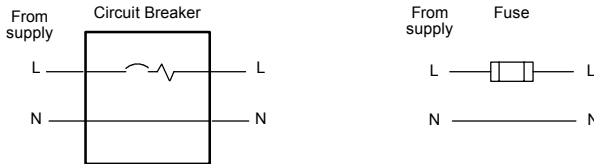
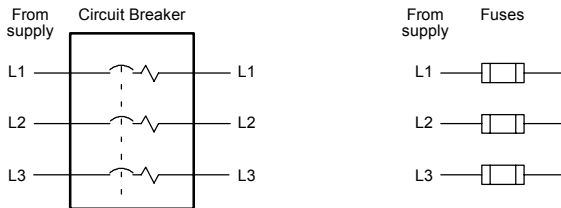

Figure 4 - Circuit breaker and fuse, single-phase



Circuit breaker or fuse are not supplied.  
For CE Compliance, see Appendix C.

Figure 5 - Circuit breaker and fuse, three-phase

**Note:** Metal conduit or shielded cable should be used. Connect conduits so the use of a line reactor or RC device does not interrupt EMI/RFI shielding.

#### 3.4.4.1 Using 2 phases of a 3-phase supply

Power may be derived by connecting two phases of an appropriate three-phase supply (L1 and L2 for example). When supplying AC power in this way, the voltage between the two phases must not exceed the rated input voltage of the MicroFlex. A two pole breaker must be used to isolate both lines. Fuses must be fitted in both lines.

### 3.4.5 Recommended fuses and wire sizes

Table 3 describes the recommended fuses and suitable wires sizes to be used for power connections.

Catalog Number	Continuous Output Amps (RMS)	AC Supply Type	Input Fuse (A)	Minimum Wire Gauge	
				AWG	mm <sup>2</sup>
FMH2A03...	3A	1Φ	Ferraz Shawmut: 6x32 FA series, 10A (W084314P) or BS88 2.5 URGS 10A (N076648)	14	2.0
		3Φ	Ferraz Shawmut: 6x32 FA series, 8A (V084313P) or BS88 2.5 URGS, 7A (M076647)	14	2.0
FMH2A06...	6A	1Φ	Ferraz Shawmut: 6x32 FA series, 20A (A084318P) or BS88 2.5 URGS, 20A (L097507)	14	2.0
		3Φ	Ferraz Shawmut: 6x32 FA series, 12.5A (X084315P) or BS88 2.5 URGS, 12A (P076649)	14	2.0
FMH2A09...	9A	1Φ	Ferraz Shawmut: BS88 2.5 URGS, 25A (R076651)	14	2.5
		3Φ	Ferraz Shawmut: 6x32 FA series, 20A (A084318P) or BS88 2.5 URGS, 20A (L097507)	14	2.0

**Table 3 - Protection device and wire ratings**

**Note:** All wire sizes are based on 75°C (167°F) copper wire. Higher temperature smaller gauge wire may be used per National Electric Code (NEC) and local codes. Recommended fuses are based on 25°C (77°F) ambient, maximum continuous control output current and no harmonic current. Earth/ground wires must be the same gauge, or larger, than the Line wires.

### 3.4.6 Drive overload protection

The MicroFlex will immediately trip and disable if there is an overload condition. The parameters for managing drive overloads are configured automatically by the Commissioning Wizard (see section 6.2.3). If they need to be changed, use the Parameters tool in WorkBench v5 (see section 6.3.2).

### 3.4.7 Power supply filters

To comply with EEC directive 89/336/EEC, an AC power filter of the appropriate type must be connected. This can be supplied by Baldor and will ensure that the MicroFlex complies with the CE specifications for which it has been tested. Ideally, one filter should be provided for each MicroFlex; filters should not be shared between drives or other equipment. Table 4 lists the appropriate filters:

MicroFlex current rating	Input voltages	
	230VAC, 1 $\Phi$	230VAC, 3 $\Phi$
3A	FI0015A00 + line reactor See sections 3.4.7.1 and 3.4.7.2.	FI0018A00
6A	FI0015A02 (see section 3.4.7.2)	FI0018A00
9A	FI0028A00	FI0018A03

**Table 4 - Baldor filter part numbers**

Maximum earth leakage from the MicroFlex is 3.4mA per phase (230V 50Hz supply). This value does not include the earth leakage from the AC power filter, which could be much larger (see section A.1.2).

#### 3.4.7.1 Harmonic suppression

When operating the 3A MicroFlex (part FMH2A03...) on a single-phase AC supply, a 13mH  $4A_{rms}$  (10A peak) line reactor is required to ensure compliance with EN61000-3-2:2000 class A limits.

#### 3.4.7.2 Reversing the filter

When using filters FI0015A00 or FI0015A02 as specified in Table 4, they must be reversed to ensure that the MicroFlex complies with the CE specifications for which it has been tested. The AC power supply should be connected to the filter terminals marked as the outputs, with the MicroFlex connected to the filter terminals marked as the inputs.



**WARNING:** This recommendation applies only to filters FI0015A00 and FI0015A02. Alternative filters or protection devices must be connected as specified by the manufacturer.

### 3.4.8 24V control circuit supply

A 24VDC supply must be provided to power the controlling electronics. This is useful for safety reasons where AC power needs to be removed from the power stage but the controlling electronics must remain powered to retain position and I/O information.

A separate fused 24V supply should be provided for the MicroFlex. If other devices are likely to be powered from the same 24V supply, a filter (Baldor catalog number FI0014A00) should be installed to isolate the MicroFlex from the rest of the system. Alternatively, a ferrite sleeve may be attached to the supply cable near connector X2.

<b>Location</b>	Connector X2
<b>Nominal input voltage</b>	24V
<b>Range</b>	20-30VDC
<b>Input current</b> Maximum Typical	1A continuous (4A typical power on surge, limited by NTC) 0.5A - 0.6A (no encoder power) 0.6A - 0.8A (if powering encoder)

Tightening torque for terminal block connections is 0.5-0.6Nm (4.4-5.3 lb-in).

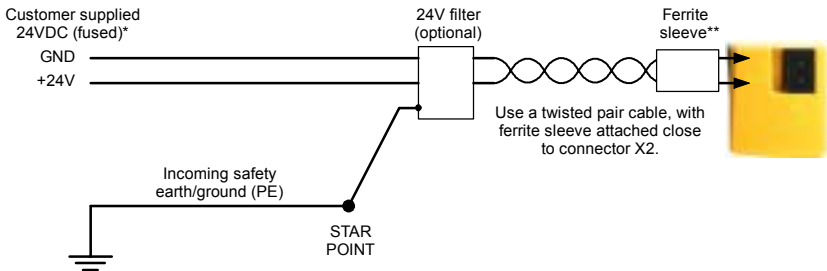

\* Recommended fuse: Bussman S504 20x5mm anti-surge 2A

\*\* Recommended ferrite sleeve: Fair-Rite part 0431164281 or similar

**Figure 6 - 24V control circuit supply connections**

### 3.5 Motor connections

MicroFlex will operate with a large number of brushless servo motors. For information on selecting Baldor servo motors please see the sales brochure BR1202, available from your local Baldor representative. The motor must be capable of being powered by an inverter PWM output - see section 8.1.3 for details. The motor can be connected directly to the MicroFlex or through a motor contactor (M-Contactor). The motor outputs are conditionally short-circuit proof. Motors should ideally have a minimum inductance of 1mH per winding; for motors with lower inductance an output reactor may be fitted in series with the motor.

When using a Baldor motor, the parameters for managing motor overloads are configured automatically by the Commissioning Wizard (see section 6.2.3). If they need to be changed, or you are using an alternative motor, use the Parameters tool in WorkBench v5 (see section 6.3.2).

Location	Connector X1		
AC supply voltage	115VAC, 1Φ	230VAC, 1Φ	230VAC, 3Φ
Output voltage range	0-115VAC, 3Φ	0-230VAC, 3Φ	0-230VAC, 3Φ

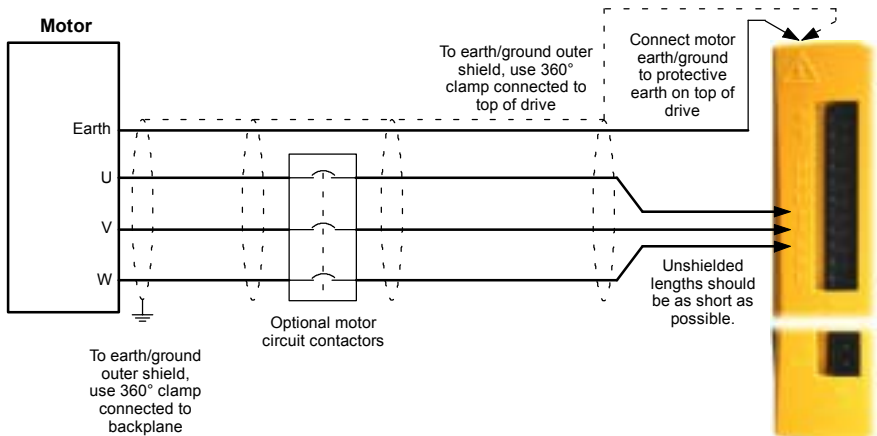

Figure 7 - Motor connections



**CAUTION:** Do not connect supply power to the MicroFlex UVW outputs. The MicroFlex might be damaged.



**CAUTION:** The motor leads U, V and W must be connected to their corresponding U, V or W terminal on the motor. Misconnection will result in uncontrolled motor movement.

The motor power cable must be shielded for CE compliance. The connector or gland used at the motor must provide 360 degree shielding. The maximum recommended cable length is 30.5m (100ft).

**Note:** For CE compliance the motor earth/ground should be connected to the drive earth/ground.

### 3.5.1 Motor circuit contactors

If required by local codes or for safety reasons, an M-Contactor (motor circuit contactor) may be installed to provide a physical disconnection of the motor windings from the MicroFlex (see section 3.5). Opening the M-Contactor ensures that the MicroFlex cannot drive the motor, which may be necessary during equipment maintenance or similar operations. Under certain circumstances, it may also be necessary to fit a brake to a rotary motor. This is important with hanging loads where disconnecting the motor windings could result in the load falling. Contact your local supplier for details of appropriate brakes.



**CAUTION:** If an M-Contactor is installed, the MicroFlex must be disabled at least 20ms before the M-Contactor is opened. If the M-Contactor is opened while the MicroFlex is supplying voltage and current to the motor, the MicroFlex may be damaged. Incorrect installation or failure of the M-Contactor or its wiring may result in damage to the MicroFlex.

Ensure that shielding of the motor cable is continued on both sides of the contactor.

### 3.5.2 Motor power cable pin configuration - Baldor BSM rotary motors

Figure 8 shows the pin configuration for a typical Baldor motor cable, part number CBL025SP-MHCE:

Signal name	Motor / cable pin	Motor cable wire color
Motor U	1	Black, labeled '1'
Motor V	4	Black, labeled '2'
Motor W	3	Black, labeled '3'
Earth/ground	2	Green/Yellow
Thermal switch	A	Green
Thermal switch	B	White
Brake	C	Blue
Brake	D	Red

Note:  
Not all motors are fitted with a brake so pins C and D might not be connected.

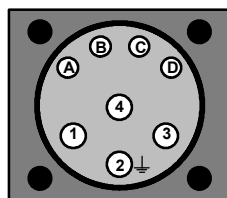

Motor power connector (male)

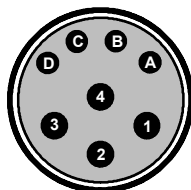

Cable connector end view (female)

Figure 8 - Baldor motor power cable pin configuration

### 3.5.3 Motor cable pin configuration - Baldor linear motors

The following table shows the pin colors used in a typical Baldor linear motor cable set, part number AY1763A00:

Signal name	Motor cable wire color
Motor U	Black
Motor V	Red
Motor W	White
Motor ground	Green
Thermal switch	Blue
Thermal switch	Orange

Signal name	Hall cable wire color
Hall 1 (U)	White
Hall 2 (V)	Red
Hall 3 (W)	Black
Hall ground	Green
Hall +5VDC	Brown

### 3.6 Regeneration resistor (Dynamic Brake resistor)

An optional external regeneration resistor may be required to dissipate excess power from the internal DC bus during motor deceleration. The regeneration resistor must have a resistance of at least  $39\Omega$ , and an inductance of less than  $100\mu\text{H}$ . Suitable regeneration resistors are listed in section A.1.3. The regeneration resistor output is conditionally short-circuit proof.

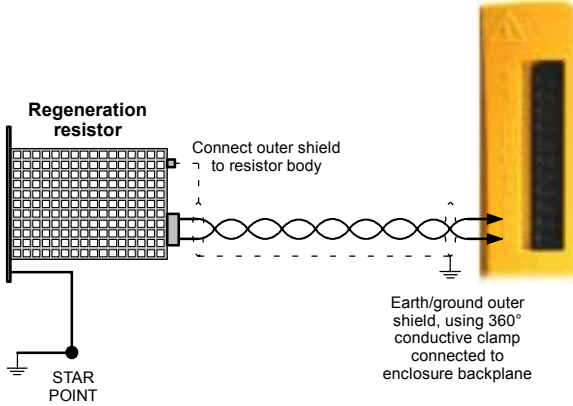

Figure 9 - Regeneration resistor connections



**DANGER:** Electrical shock hazard. DC bus voltages may be present at these terminals. A regeneration resistor may generate enough heat to ignite combustible materials. To avoid fire hazard, keep all combustible materials and flammable vapors away from the resistor.

## 4.1 Introduction

Two feedback options are available for use with linear and rotary motors; incremental encoder, or encoder with SSI (Synchronous Serial Interface). There are some important considerations when wiring the feedback device:

- The feedback device wiring must be separated from power wiring.
- Where feedback device wiring runs parallel to power cables, they must be separated by at least 76mm (3 in)
- Feedback device wiring must cross power wires at right angles only.
- To prevent contact with other conductors or earths/grounds, unearthed/ungrounded ends of shields must be insulated.
- Linear motors use two separate cables (encoder and Hall). The cores of these two cables will need to be wired to the appropriate pins of the 15-pin D-type mating connector.

An encoder output signal is available on connector X7 for supplying other equipment.

### 4.1.1 Encoder feedback - X8

The encoder connections (ABZ channels and Hall signals) are made using the 15-pin D-type female connector X8. Twisted pair cables must be used for the complementary signal pairs e.g. CHA+ and CHA-. The Hall inputs may be used as differential inputs (recommended for improved noise immunity) or single ended inputs. When used as single ended inputs, leave the Hall U-, Hall V- and Hall W- pins unconnected. The overall cable shield (screen) must be connected to the metallic shell of the D-type connector. Connector X8 includes a 'Sense' pin, which is used to detect the voltage drop on long cable runs. This allows the MicroFlex to increase the encoder supply voltage on pin 12 to maintain a 5V supply at the encoder.

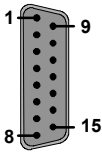

Location	Connector X8 15-pin D-type female connector (not high density)
Pin	Encoder function
1	CHA+
2	CHB+
3	CHZ+
4	Sense
5	Hall U-
6	Hall U+
7	Hall V-
8	Hall V+
9	CHA-
10	CHB-
11	CHZ-
12	+5V out
13	DGND
14	Hall W-
15	Hall W+
Description	Incremental (UVW) encoder input, non-isolated. Pin 12 provides 5-11V for encoders requiring power (200mA max)

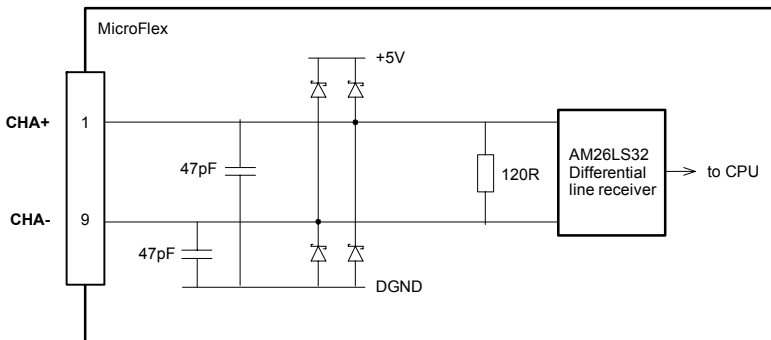

Figure 10 - Encoder channel input circuit - Channel A shown

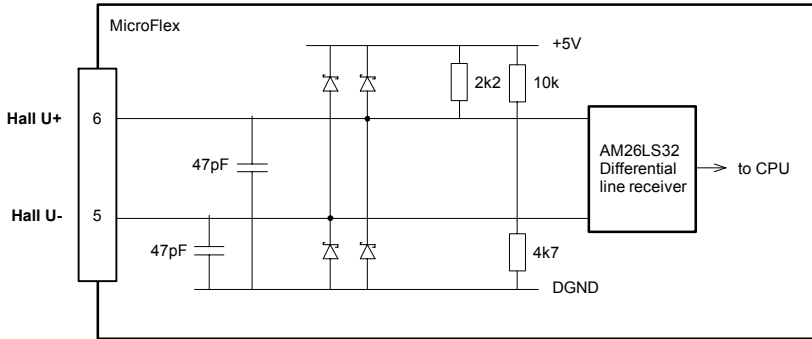

Figure 11 - Hall channel input circuit - U phase shown

#### 4.1.1.1 Encoder cable configuration - Baldor rotary motors

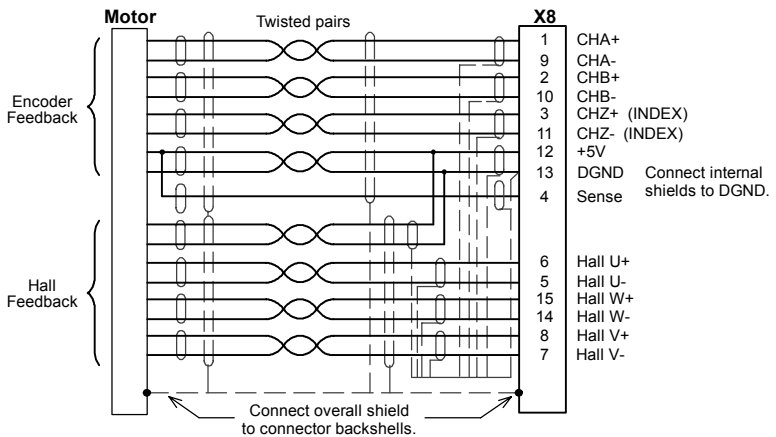

Figure 12 - Encoder cable connections - rotary motors

**Note:** If the Hall inputs are used as single ended inputs, leave the Hall U-, Hall V- and Hall W- pins unconnected; do not connect them to ground.

#### 4.1.1.2 Encoders without Halls

Incremental encoders without Hall feedback connections may be connected to the MicroFlex. However, if Hall connections are not present, it will be necessary for the MicroFlex to perform an automatic phase search sequence each time it is powered. This will cause motor movement of up to 1 turn on rotary motors, or one pole-pitch on linear motors.

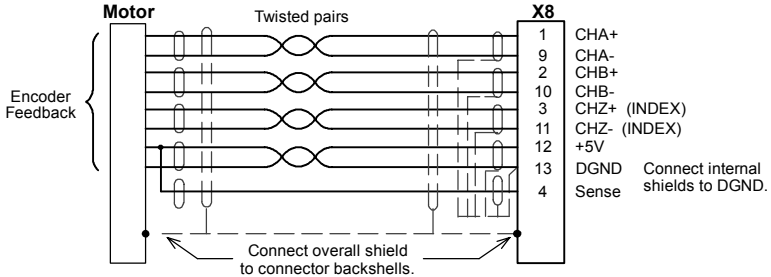

Figure 13 - Encoder cable connections without halls - rotary motors

#### 4.1.1.3 Halls-only feedback devices

Feedback devices using only Hall sensors may be connected to the MicroFlex. However, since there are no encoder connections, the MicroFlex will not be able to perform smooth speed control or accurate positioning control.

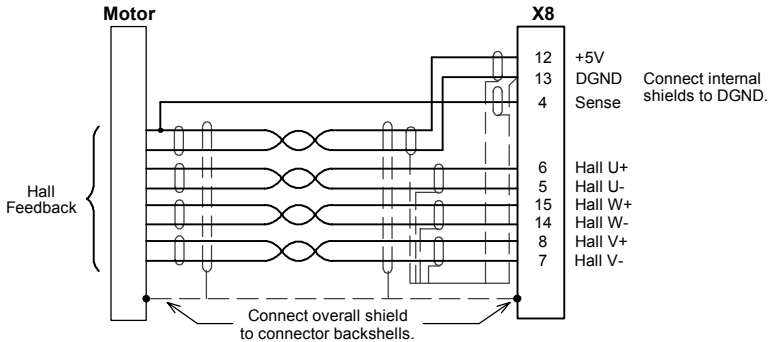

Figure 14 - Halls-only feedback cable connections - rotary motors

**Note:** If the Hall inputs are used as single ended inputs, leave the Hall U-, Hall V- and Hall W- pins unconnected; do not connect them to ground.

#### 4.1.1.4 Encoder cable pin configuration - Baldor linear motors

Baldor linear motors use two separate cables (encoder and Hall). The cores of these two cables must be wired to the appropriate pins of the 15-pin D-type mating connector (supplied):

Signal name	MicroFlex X8 pin	Encoder cable internal wire colors
<b>CHA+</b>	1	Please refer to MN1800 <i>Linear Motors Installation &amp; Operating Manual</i> for details.
<b>CHA-</b>	9	
<b>CHB+</b>	2	
<b>CHB-</b>	10	
<b>CHZ+</b>	3	
<b>CHZ-</b>	11	
		Baldor Hall cable internal wire colors
<b>Hall U+</b>	6	White
<b>Hall V+</b>	8	Red
<b>Hall W+</b>	15	Black
<b>+5V</b>	12	Brown
<b>Hall GND</b>	13	Green

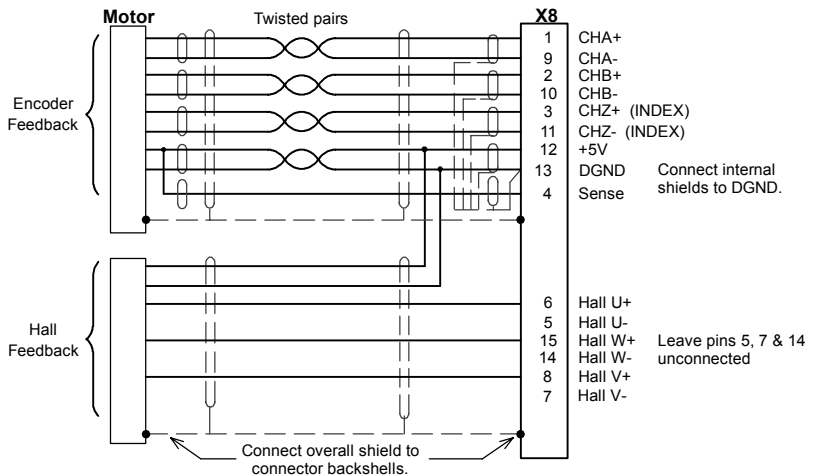
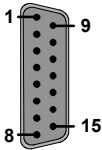

Figure 15 - Encoder cable connections - linear motors

## 4.1.2 SSI feedback - X8

The SSI (Synchronous Serial Interface) encoder interface is specifically designed for use with Baldor SSI motors, which incorporate a custom Baumer SSI encoder. Correct operation with other SSI interfaces cannot be guaranteed. The SSI encoder connections are made using the 15-pin D-type female connector X8. Twisted pair cables must be used for the complementary signal pairs e.g. Data+ and Data-. The overall cable shield (screen) must be connected to the metallic shell of the D-type connector. Connector X8 includes a 'Sense' pin, which is used to detect the voltage drop on long cable runs. This allows the MicroFlex to increase the encoder supply voltage on pin 12 to maintain a 5V supply at the encoder.



Location	Connector X8, 15-pin D-type female connector
Pin	Encoder function
1	Data+
2	Clock+
3	(NC)
4	Sense
5	(NC)
6	(NC)
7	(NC)
8	(NC)
9	Data-
10	Clock-
11	(NC)
12	5-11V out
13	DGND
14	(NC)
15	(NC)
Description	SSI encoder input, non-isolated. Pin 12 provides power to the encoder (200mA max).

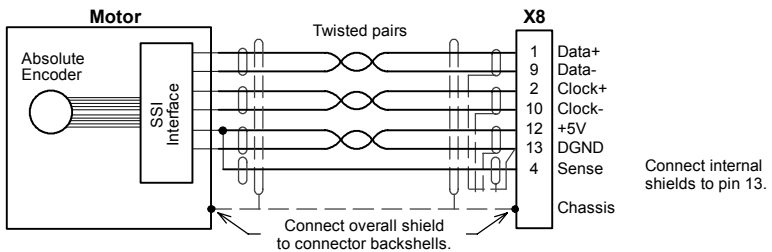
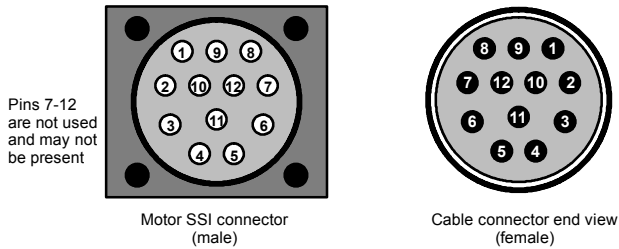

Figure 16 - SSI encoder cable connections

#### 4.1.2.1 SSI cable pin configuration

Figure 17 shows the pin configuration for a typical Baldor SSI feedback cable, part number CBL025SF-ALCE.

Signal name	MicroFlex X8 pin	Motor / cable pin	Baldor SSI cable internal wire colors
5-11V out	12	1	Red
Sense	4	1	Orange
DGND	13	2	Blue
Clock+	2	3	Pink
Clock-	10	4	Grey
Data+	1	5	Green
Data-	9	6	Yellow



**Figure 17 - Baldor motor SSI feedback cable pin configuration**

The maximum recommended cable length is 30.5m (100ft).

### 4.1.3 Encoder output - X7

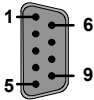

Location	Connector X7
Pin	Name
1	CHA+
2	CHB+
3	CHZ+
4	(NC)
5	DGND
6	CHA-
7	CHB-
8	CHZ-
9	(NC)
Description	Encoder output on a 9-pin female D-type connector

This output can be used for position feedback to a host positioner, or in master/slave situations where the axis movement can be transmitted to another controller. It is recommended that this output only drives one output circuit load. The encoder outputs are differential and conform to the RS422 electrical specification. Shielded twisted pair cable is recommended.

If the MicroFlex is configured for incremental encoder feedback, X7 duplicates the encoder signals entering X8. If operating in Halls-only mode, there will be no encoder output at X7.

If the MicroFlex is configured for SSI feedback, a simulated encoder output is produced at X7. The default simulated encoder output resolution is 16384 counts per revolution, but this can be altered using the Drive Setup Wizard in WorkBench v5. At 62.5 microsecond intervals (a 16kHz sampling rate), the simulated encoder output generates a burst of A and B pulses (and a Z pulse if required). The frequency and length of the burst is varied to represent the change in the input encoder's position during the preceding 62.5 microsecond interval. See the keyword ENCODERLINESOUT in the Mint help file.

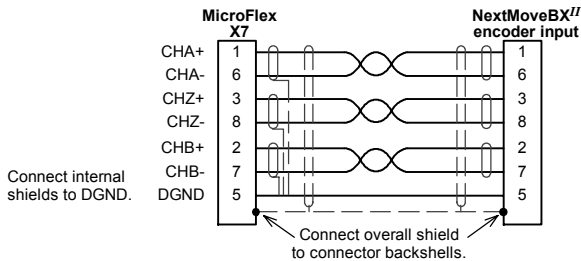

Figure 18 - MicroFlex encoder output to Mint controller encoder input

## 5.1 Introduction

This section describes the various digital and analog input and output capabilities of the MicroFlex, with descriptions of each of the connectors on the front panel.

The following conventions are used to refer to the inputs and outputs:

I/O ..... Input / Output  
DIN ..... Digital Input  
DOUT ..... Digital Output  
AIN ..... Analog Input

## 5.2 Analog I/O

The MicroFlex provides as standard:

- 1 analog input on the connector block X3 (demand input)

### 5.2.1 Analog input - X3 (demand)

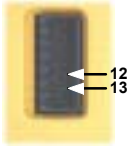

<b>Location</b>	Connector X3, pins 12 & 13 (Mating connector: Weidmüller Minimate B2L 3.5/14)
<b>Name</b>	AIN0
<b>Description</b>	Single ended or differential input. Common mode voltage range: $\pm 10\text{VDC}$ . Resolution: 12-bit (accuracy $\pm 4.9\text{mV}$ ) Common mode rejection: 40dB Input impedance: $>30\text{k}\Omega$ Sampling interval: $125\mu\text{s}$

The analog input can be connected as either a differential or a single ended input as shown in Figure 20. The analog input is not optically isolated from internal power rails, so care must be taken to avoid earth/ground loops and similar associated problems. The input buffers provide low pass filtering of the applied voltage. To minimize the effects of noise, the analog input signal should be connected to the system using an individually shielded twisted pair cable with an overall shield. The overall shield should be connected to the chassis at one end only. No other connection should be made to the shield.

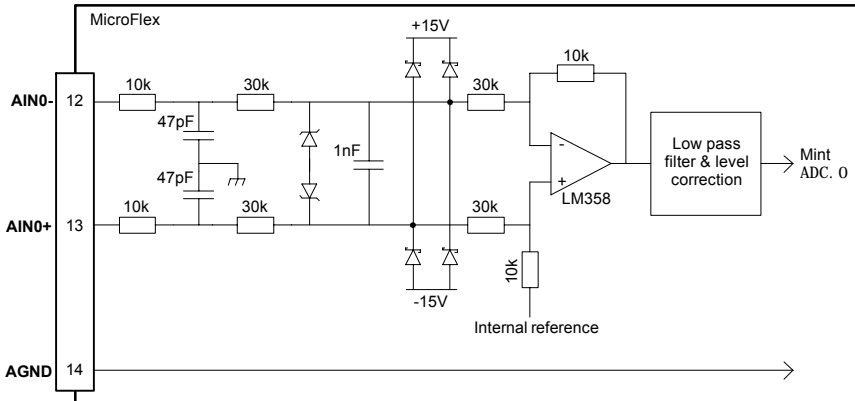

Figure 19 - AIN0 analog input (demand) circuit

When the MicroFlex is connected to WorkBench v5, the analog input value (expressed as a percentage) can be viewed using the Spy window's Monitor tab. Alternatively, the command `Print ADC. 0` can be used in the command window to return the value of the analog input. See the Mint help file for details.

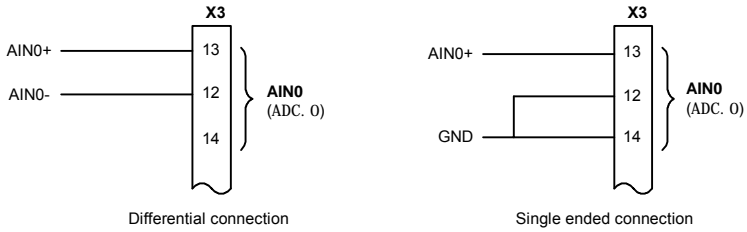

Figure 20 - AIN0 analog input wiring

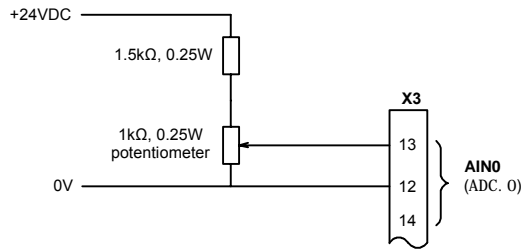

Figure 21 - Typical input circuit to provide 0-10V (approx.) input from a 24V source

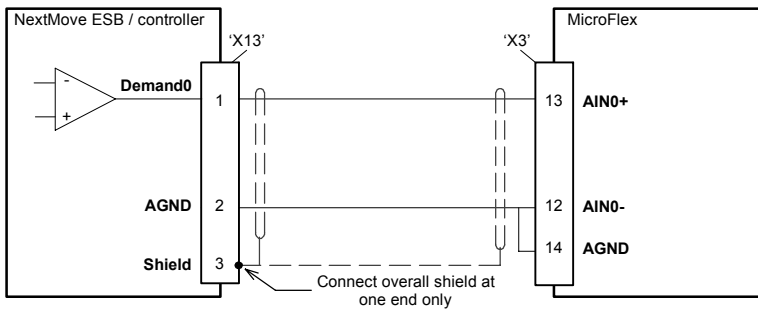

Figure 22 - Analog input - typical connection from a Baldor NextMove ESB

## 5.3 Digital I/O

The MicroFlex provides as standard:

- 1 dedicated drive enable input.
- 1 general purpose digital input.
- Dedicated step and direction inputs.
- 1 dedicated drive status output.

The general purpose digital input can be configured for typical input functions:

- Error input
- Reset input
- Stop input.

### 5.3.1 Drive enable input - X3

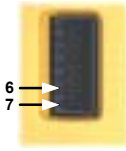

<b>Location</b>	Connector X3, pins 6 & 7 (Mating connector: Weidmüller Minimate B2L 3.5/14)
<b>Name</b>	Drive enable
<b>Description</b>	Dedicated drive enable input. Nominal input voltage: +24VDC (input current not to exceed 50mA)

The drive enable input is buffered by a TLP280 opto-isolator, allowing the input signal to be connected with either polarity.

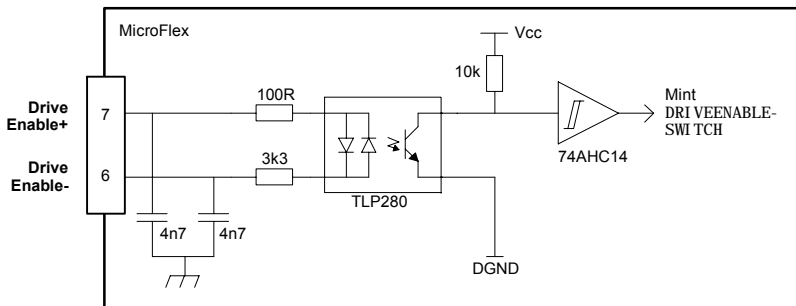

**Figure 23 - Drive enable input circuit**

In normal use, the drive enable input controls the enabled status of the drive. However, when the MicroFlex is connected to WorkBench v5, additional methods are available for controlling the drive enable status. In all cases, the drive enable input must be active and there must be no errors present before the MicroFlex can be enabled.

- The drive enable button  on the motion toolbar toggles the enable/disable status. Alternatively, the Mint command DRI VEENABLE. 0=1 can be used in the command window to enable the MicroFlex; DRI VEENABLE. 0=0 will disable the MicroFlex.
- The Tools, Reset Controller menu item will clear errors and enable the MicroFlex. Alternatively, the Mint command RESET. 0 can be used in the command window to perform the same action.

The state of the drive enable input is displayed in the WorkBench v5 Spy window. Alternatively, the state of the drive enable input can be read (but not set) using the Mint command `Print DRI VEENABLESWI TCH` in the command window. See the Mint help file for details.

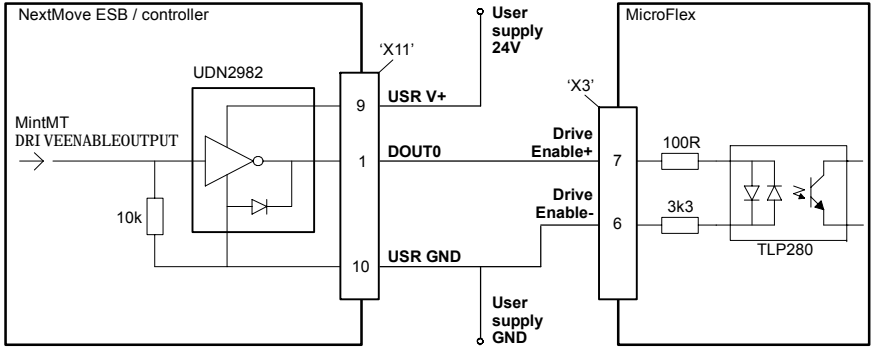
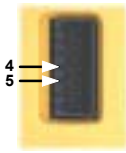

Figure 24 - Drive enable input - typical connection from a Baldor NextMove ESB

### 5.3.2 General purpose digital input - X3



<b>Location</b>	Connector X3, pins 4 & 5 (Mating connector: Weidmüller Minimate B2L 3.5/14)
<b>Name</b>	DINO
<b>Description</b>	General purpose optically isolated digital input. Nominal input voltage: +24VDC (input current not to exceed 50mA) Sampling interval: 500µs

The general purpose digital input is buffered by a TLP280 opto-isolator, allowing the input signal to be connected with either polarity. The state of the digital input is displayed in the WorkBench v5 Spy window. The input can be configured for different user definable functions.

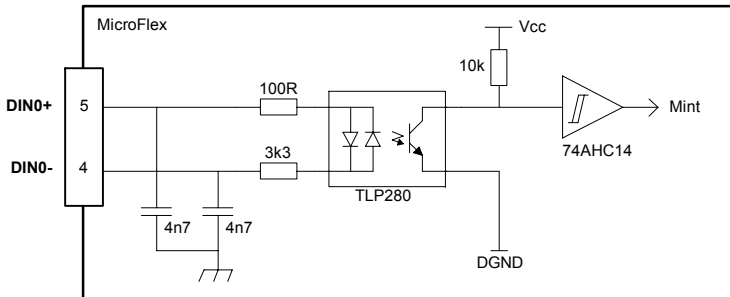

**Figure 25 - General purpose digital input circuit**

When the MicroFlex is connected to WorkBench v5, the digital input can be configured using the Operating Mode Wizard. Alternatively, the Mint keywords `RESETI NPUT`, `ERRORI NPUT` and `STOPI NPUT` can be used in the command window. See the Mint help file for details.

The state of the digital input can be viewed using the Spy window's Axis tab.

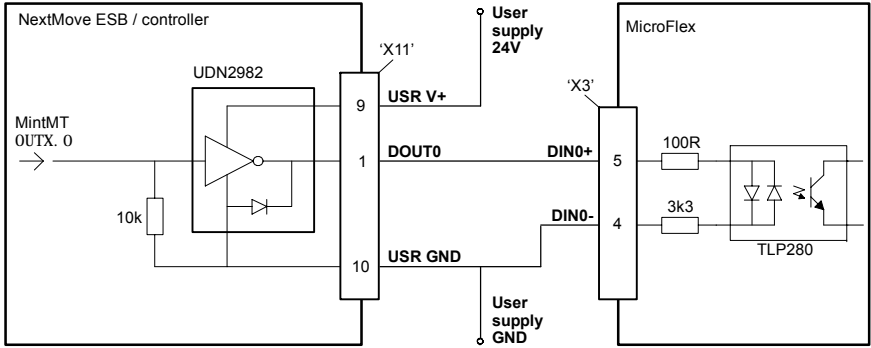
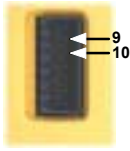

Figure 26 - Digital input - typical connection from a Baldor NextMove ESB

### 5.3.3 Step (pulse) and direction inputs - X3



<b>Location</b>	Connector X3, pins 9 & 10 (Mating connector: Weidmüller Minimate B2L 3.5/14)
<b>Names</b>	Step and Dir
<b>Description</b>	Dedicated step and direction inputs. Input voltage: +5VDC Maximum input frequency: 1 MHz maximum

When the MicroFlex control mode is set to position control, the step and direction inputs are used as the demand reference.

Pin 10 is the step input. The step frequency controls the speed of the motor.

Pin 9 is the direction input. The state of the direction input controls the direction of motion. If +5V is present on pin 9, movement will be in the forward direction. If pin 9 is grounded, movement will be in the opposite direction.

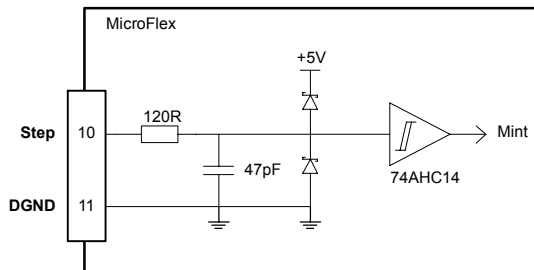

**Figure 27 - Step and direction input circuit - Step shown**

When the MicroFlex is connected to WorkBench v5, the following ratio can be configured using the Operating Mode Wizard. Alternatively, the Mint keywords FOLLOWDENOM and FOLLOWNUMERATOR can be used in the command window. See the Mint help file for details.

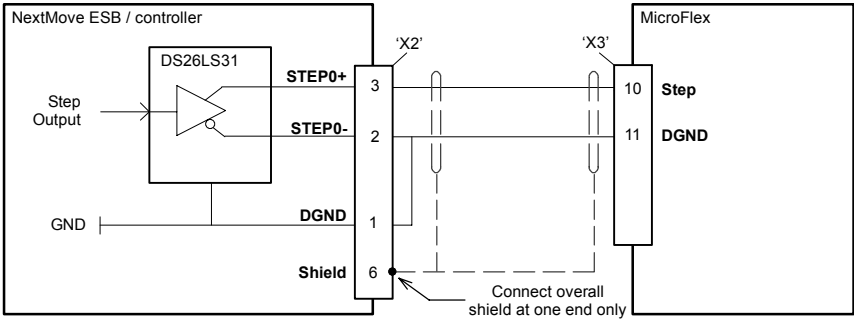
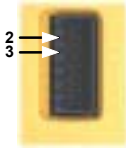

Figure 28 - Stepper input - typical connection from a Baldor NextMove ESB

### 5.3.4 Status output - X3



<b>Location</b>	Connector X3, pins 2 & 3 (Mating connector: Weidmüller Minimate B2L 3.5/14)
<b>Name</b>	Status
<b>Description</b>	Opto-isolated status output Output current: 100mA maximum User supply 30VDC maximum Update interval: 500µs

The optically isolated status output is designed to source current from the user supply as shown in Figure 29. The PS2562L has a maximum power dissipation of 200mW at 25°C. The maximum saturated voltage across the outputs when active is 1.0VDC, so it can be used as a TTL compatible output.

The output includes a self-resetting fuse that operates at approximately 200mA. The fuse may take up to 20 seconds to reset after the load has been removed. If the output is used to directly drive a relay, a suitably rated diode must be fitted across the relay coil, observing the correct polarity. This is to protect the output from the back-EMF generated by the relay coil when it is de-energized. The sense of the output can be configured in WorkBench v5, and its state is displayed in the Spy window.

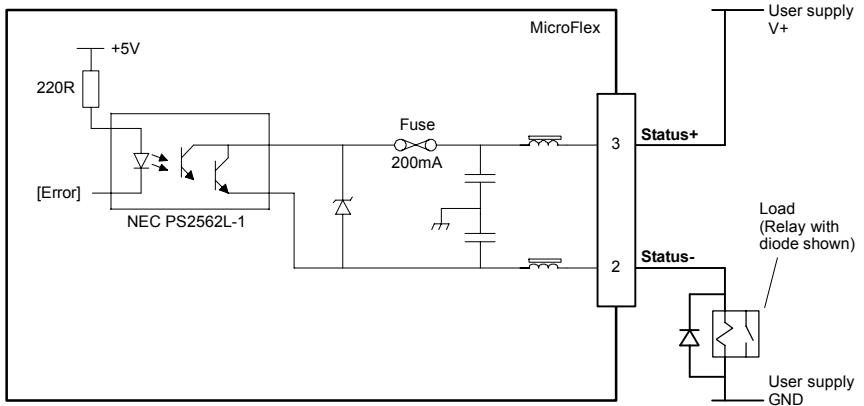

**Figure 29 - Drive status output circuit**

When the MicroFlex is connected to WorkBench v5, the active level of the output can be configured using the Operating Mode Wizard. Alternatively, the Mint keyword `OUTPUTACTIVELEVEL` can be used in the command window. See the Mint help file for details.

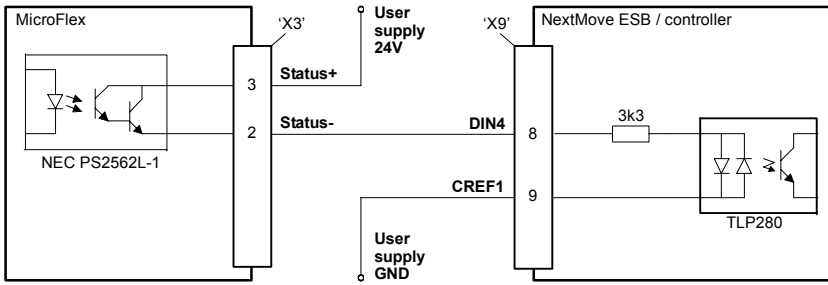

Figure 30 - Status output - typical connections to a Baldor NextMove ESB

## 5.4 Serial port - X6



Location	Connector X6	
Pin	RS232 name	RS485 / RS422 name
1	(NC)	(NC)
2	RXD	RX- (input)
3	TXD	TX- (output)
4	(NC)	(NC)
5	0V GND	0V DGND
6	(NC)	(NC)
7	RTS	TX+ (output)
8	CTS	RX+ (input)
9	(NC)	(NC)
<b>Description</b>	RS232 or RS485 / RS422 connections on a 9-pin male D-type connector	

MicroFlex is available with either an RS232 or RS485 serial port (see section 2.2.1). The port is fully ESD protected to IEC 1000-4-2 (15kV).

### 5.4.1 Using RS232 cable

The MicroFlex has a full-duplex RS232 serial port with the following preset configuration:

- 57.6 Kbaud
- 1 start bit
- 8 data bits
- 1 stop bit
- No parity
- Hardware handshaking lines RTS and CTS must be connected.

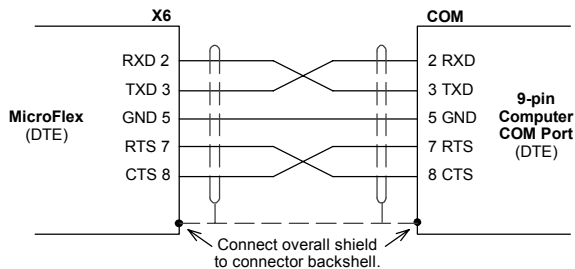

**Figure 31 - RS232 serial port connections**

When the MicroFlex is connected to WorkBench v5, the Tools, Options menu item can be used to configure the serial port. The configuration can also be changed using the Mint keyword SERI ALBAUD (see the Mint help file for details).

The RS232 port is configured as a DTE (Data Terminal Equipment) unit. Both the output and input circuitry are single ended and operate between  $\pm 12V$ . The port is capable of operation at up to 57.6 Kbaud. The maximum recommended cable length is 3m (10ft) at 57.6 Kbaud (the factory preset rate). When using lower baud rates, longer cable lengths may be used up to maximum of 15m (49ft) at 9600 baud.

## 5.4.2 Multidrop using RS485 / RS422 cable

Multidrop systems allow one device to act as a 'network master', controlling and interacting with the other (slave) devices on the network. The network master can be a controller such as MicroFlex, a host application such as WorkBench v5 (or other custom application), or a programmable logic controller (PLC). RS422 may be used for multi-drop applications as shown in Figure 32. Four-wire RS485 may be used for single point-to-point applications involving only one Baldor controller. If firmware is updated over RS485/RS422, it can only be downloaded to the drive that was chosen in the Select Controller dialog in WorkBench v5.

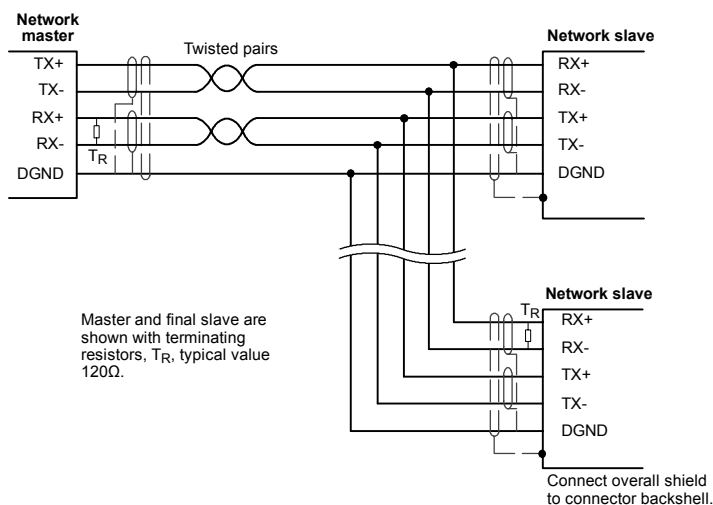

Figure 32 - 4-wire RS422 multi-drop connections

Each transmit/receive (TX/RX) network requires a termination resistor at the final RX connection, but intermediate devices must not be fitted with termination resistors. An exception is where repeaters are being used which may correctly contain termination resistors. Termination resistors are used to match the impedance of the load to the impedance of the transmission line (cable) being used. Unmatched impedance causes the transmitted signal to not be fully absorbed by the load. This causes a portion of the signal to be reflected back into the transmission line as noise. If the source impedance, transmission line impedance, and load impedance are all equal, the reflections (noise) are eliminated. Termination resistors increase the load current and sometimes change the bias requirements and increase the complexity of the system.

### 5.4.3 Connecting serial Baldor HMI Operator Panels

Serial Baldor HMI Operator Panels use a 15-pin male D-type connector (marked PLC PORT), but the MicroFlex connector X6 is a 9-pin male D-type connector. The MicroFlex may be connected with or without hardware handshaking, as shown in Figure 33:

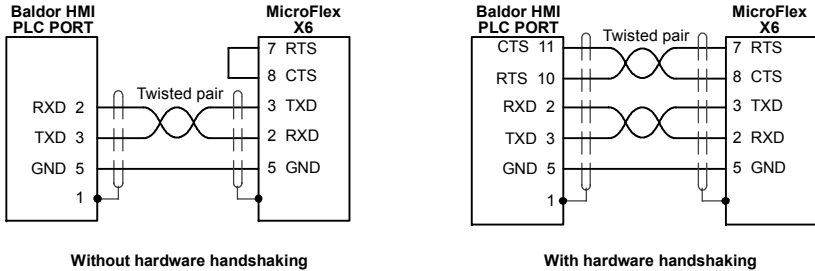

Figure 33 - RS232 cable wiring

Alternatively, the Baldor HMI panel may be connected using RS485/422, as shown in Figure 34:

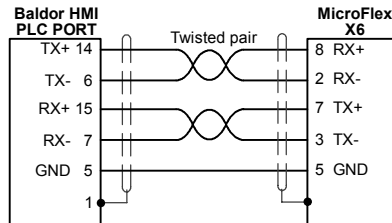
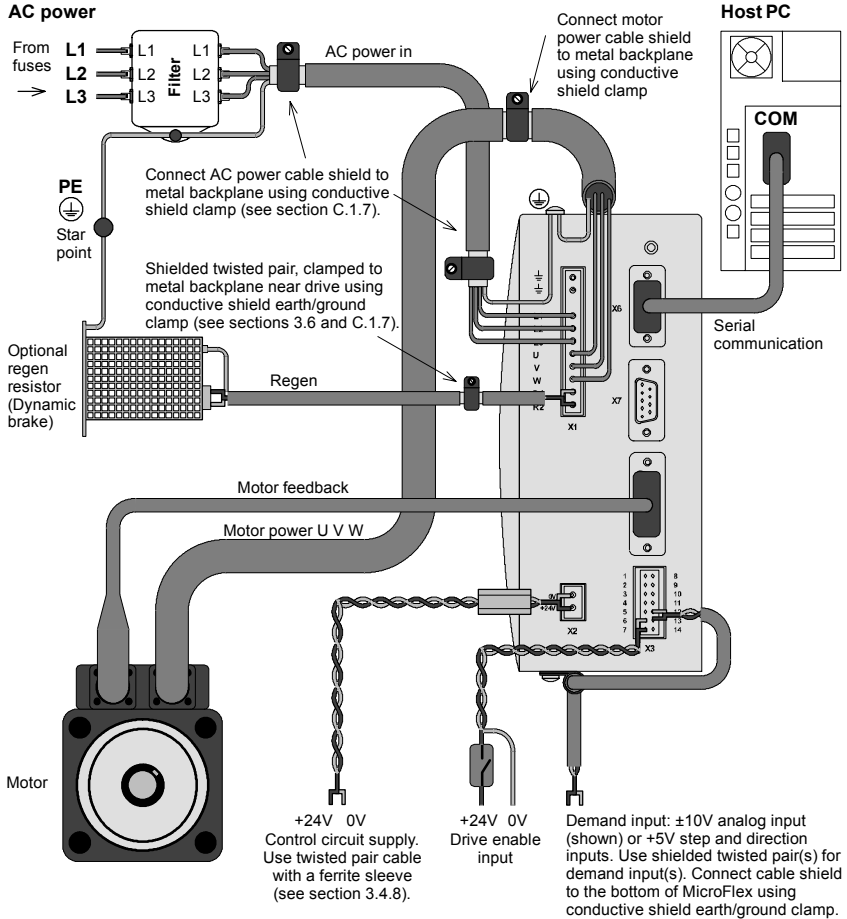

Figure 34 - RS485/422 cable wiring

## 5.5 Connection summary - recommended system wiring

As an example, Figure 35 shows the recommended wiring necessary for the MicroFlex to control a motor, while conforming to the EMC requirements for 'industrial' environments.



- The MicroFlex should be mounted on an earthed metal backplane.
- Ensure cables do not obstruct airflow to the heatsink.
- Motor represents a typical Baldor BSM motor. Linear motors may also be controlled by MicroFlex.
- Conductive shield earth/ground clamps are not supplied.
- When using single phase supplies it may be necessary to reverse the AC power filter - see section 3.4.7.2.

**Figure 35 - Recommended system wiring**

## 6.1 Introduction

Before powering the MicroFlex you will need to connect it to the PC using a serial cable and install the supplied PC software *WorkBench v5*. This software includes a number of tools to allow you to configure and tune the MicroFlex. If you do not have experience of software installation or Windows applications you may need further assistance for this stage of the installation.

### 6.1.1 Connecting the MicroFlex to the PC

Connect the serial cable between a PC serial port (often labeled as "COM") and the MicroFlex connector X6. WorkBench v5 can scan all the COM ports, so you can use any port.

### 6.1.2 Installing the software

The *Baldor Motion Toolkit* CD containing the software can be found separately within the packaging.

1. Insert the CD into the PC's drive.
2. After a few seconds the setup wizard should start automatically. If the setup wizard does not appear, select Run... from the Windows Start menu and type

**d:\start**

where **d** represents the drive letter of the CD device (use the correct letter for your installation).

Follow the on-screen instructions to install WorkBench v5. The setup wizard will copy the files to appropriate folders on the hard drive. The default folder is C:\Program Files\Baldor\MintMT, although this can be changed during setup.

### 6.1.3 Starting the MicroFlex

If you have followed the instructions in the previous sections, you should now have connected all the power sources, inputs and outputs, and the serial cable linking the PC to the MicroFlex.

### 6.1.4 Preliminary checks

Before you apply power for the first time, it is very important to verify the following:

- Disconnect the load from the motor until instructed to apply a load. If this cannot be done, disconnect the motor wires at connector X1.
- Verify that the AC line voltage matches the specification of the MicroFlex.
- Inspect all power connections for accuracy, workmanship and tightness.
- Verify that all wiring conforms to applicable codes.
- Verify that the MicroFlex and motor are properly earthed/grounded.
- Check all signal wiring for accuracy.

### 6.1.5 Power on checks

If at any time the Status LED flashes red, the drive has detected a fault - see section 7.

1. Turn on the 24VDC supply.
2. Turn on the AC supply.
3. After a brief test sequence, the Status LED should be green.

If the LED is not lit then re-check the power supply connections.

4. If the motor wires were disconnected in section 6.1.4, turn off the AC supply and reconnect the motor wires. Turn on the AC supply.
5. To allow the Commissioning Wizard to function, the drive enable signal will need to be present on connector X3 to allow the MicroFlex to be enabled (see section 5.3.1.). If you do not wish to enable the MicroFlex yet, the Commissioning Wizard will inform you when this step is necessary.

The MicroFlex is now ready to be commissioned using WorkBench v5.

## 6.2 WorkBench v5

WorkBench v5 is a fully featured application for commissioning the MicroFlex. The main WorkBench v5 window contains a menu system, the Toolbox and other toolbars. Many functions can be accessed from the menu or by clicking a button - use whichever you prefer. Most buttons include a 'tool-tip'; hold the mouse pointer over the button (don't click) and its description will appear.

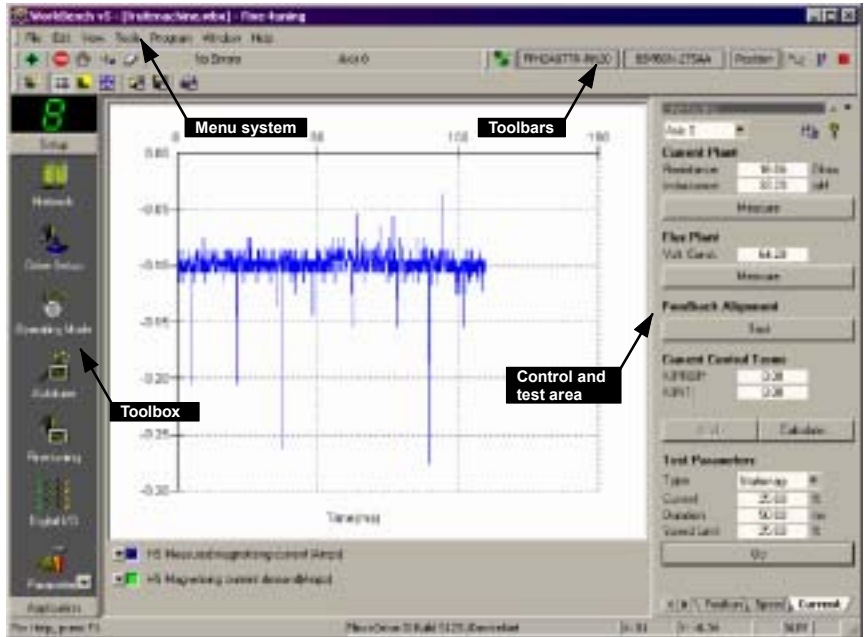



Figure 36 - The WorkBench v5 software

## 6.2.1 Help file

WorkBench v5 includes a comprehensive help file that contains information about every Mint keyword, how to use WorkBench v5 and background information on motion control topics. The help file can be displayed at any time by pressing F1. On the left of the help window, the Contents tab shows the tree structure of the help file. Each book icon contains a number of topics. The Index tab provides an alphabetic list of all topics in the file, and allows you to search for them by name. The Search tab allows you to search for words or phrases appearing anywhere in the help file. Many words and phrases are underlined and highlighted with a color (normally blue) to show that they are links. Just click on the link to go to an associated keyword. Most keyword topics begin with a list of relevant *See Also* links.



Figure 37 - The WorkBench v5 help file

For help on using WorkBench v5, click the **Contents** tab, then click the small plus sign  beside the **WorkBench v5** book icon. Double click a  topic name to display it.

## 6.2.2 Starting WorkBench v5

1. On the Windows **Start** menu, select Programs, WorkBench v5, WorkBench.

WorkBench v5 will start, and the Tip of the Day dialog will be displayed.

You can prevent the Tip of the Day dialog appearing next time by removing the check mark next to Show tips at startup.

Click **Close** to continue.



2. In the opening dialog box, click **Start New Project...**



- In the Select Controller dialog, go to the drop down box near the top and select the PC serial port to which the MicroFlex is connected.

(If you are unsure which PC serial port is connected to the MicroFlex, select **Scan all serial ports**).

Click **Scan** to search for the MicroFlex.

When the search is complete, click on MicroFlex in the list to select it, and click the **Select** button.



This check box is already selected for you. When you click **Select**, it means that the Commissioning Wizard will start automatically.

**Note:** If the MicroFlex is not listed, check the serial lead between the MicroFlex and the PC and that the MicroFlex is powered correctly. Click **Scan** to re-scan the ports.

### 6.2.3 Commissioning Wizard

Each type of motor and drive combination has different performance characteristics. Before the MicroFlex can be used to control the motor accurately, the MicroFlex must be “tuned”. This is the process where the MicroFlex powers the motor in a series of tests. By monitoring the feedback from the motor’s encoder and performing a number of calculations, the MicroFlex can make small adjustments to the way it controls the motor. This information is stored in the MicroFlex and can be uploaded to a file if necessary.

The Commissioning Wizard provides a simple way to tune the MicroFlex and create the necessary configuration information for your drive/motor combination, so this is the first tool that should be used. However, if necessary any of the parameters set by the Commissioning Wizard can be adjusted manually after commissioning is complete.

### 6.2.4 Using the Commissioning Wizard



**CAUTION:** The motor will move during commissioning. For safety it is advisable to disconnect any load from the motor during initial commissioning. The motor can be tuned with the load connected after the Commissioning Wizard has finished.

Each screen of the Commissioning Wizard requires you to enter information about the motor or drive. Read each screen carefully and enter the required information.

If you need extra help, click the **Help** button or press F1 to display the help file.

When you have completed a screen, click **Next >** to display the next screen. If you need to change something on a previous screen, click the **< Back** button. The Commissioning Wizard remembers information that you have entered so you will not need to re-enter everything if you go back to previous screens.

During commissioning, changed parameters are stored in the MicroFlex’s volatile memory. For this reason, the Commissioning Wizard will occasionally prompt you to save the parameters. Selecting **Yes** will cause the parameters to be saved in the MicroFlex’s non-volatile flash memory, to be retained when power is removed. If you select **No**, you must remember to use the *Save Drive Parameters* function before removing power from the MicroFlex; this function is available on the Tools menu, or by clicking the  button on the Mode toolbar. Saving parameters into flash memory will cause the MicroFlex to be reset.

## 6.3 Further configuration

WorkBench v5 provides a number of tools, each of which has an icon on the left of the screen. Click once on an icon to select the tool. Three of the main tools used for tuning and configuring the MicroFlex are described in the following sections.

Every tool is explained fully in the help file. Press F1 to display the help file, then navigate to the WorkBench v5 book. Inside this is the Toolbox book.

### 6.3.1 Fine-tuning tool

The Commissioning Wizard calculates many parameters that allow the MicroFlex to provide basic control of the motor. These parameters may need to be fine-tuned to provide the exact response that you require. The Fine-tuning screen allows you to do this.

1. Click the Fine-tuning icon in the Toolbox on the left of the screen.

The Fine-tuning window is displayed at the right of the screen. This already shows some of the parameters that have been calculated by the Commissioning Wizard.



The main area of the WorkBench v5 window displays the capture window. When further tuning tests are performed, this will display a graph representing the response.

2. The Fine-tuning window has three tabs at the bottom - Step, Speed and Current. Click on a tab to select it.

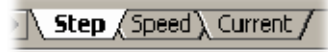

Click the tab for the type of tests you wish to perform.

**Note:** Some tabs may not be available depending on the configuration mode you selected in the Commissioning Wizard.

### 6.3.1.1 Fine-tuning - Step tab

The Step tab allows you to adjust position loop settings and perform test moves. The Commissioning Wizard may have already set some of these values, depending on the type of system selected on the mode screen.

Enter new values in the required boxes and then click **Apply** to download the values to the MicroFlex. To perform tests, go to the Test Parameters area at the bottom of the tab. Enter test values and then click **Go** to perform the test move. If you need help, just press F1 to display the help file.

### 6.3.1.2 Fine-tuning - Speed tab

The Speed tab allows you to set speed loop gains and perform test moves. The Commissioning Wizard may have already set some of these values, depending on the type of system selected on the mode screen.

Enter new values in the required boxes and then click **Apply** to download the values to the MicroFlex. To perform tests, go to the Test Parameters area at the bottom of the tab. Enter test values and then click **Go** to perform the test move. If you need help, just press F1 to display the help file.

### 6.3.1.3 Fine-tuning - Current tab

The Current tab allows you to set current loop gains and perform test moves. The Commissioning Wizard may have already set some of these values, depending on the type of system selected on the mode screen. Normally, it should not be necessary to alter these values.

Enter new values in the required boxes and then click **Apply** to download the values to the MicroFlex. To perform tests, go to the Test Parameters area at the bottom of the tab. Enter test values and then click **Go** to perform the test move. If you need help, just press F1 to display the help file.

The additional **Measure** and **Feedback alignment** buttons can be used to repeat the same measurement and alignment tests as the Commissioning Wizard.

## 6.3.2 Parameters tool

The Parameters tool can be used to setup many important parameters, such as a scaling factor for the feedback input, and the action to take when errors occur.

1. Click the Parameters icon in the Toolbox on the left of the screen.

The main area of the WorkBench v5 window displays the Controller Parameters screen.



2. The Controller Parameters screen has a number of tabs listed on the left. Click on a tab to select it.

If you need help with any of the options, just press F1 to display the help file.

Remember to click the tab's **Apply** button to send the changes to the MicroFlex.

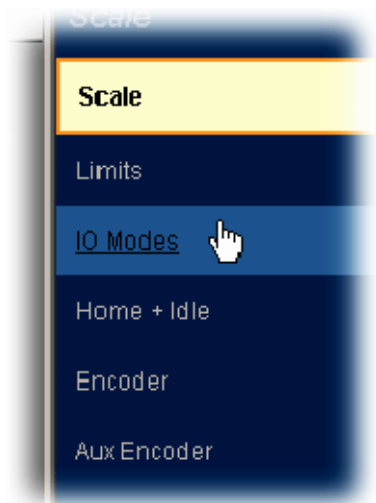

### 6.3.3 Other tools and windows

Each tool and window is explained fully in the help file, so is not described here in detail.

- **Edit & Debug Tool**  
 This tool provides a work area including the Command window and Output window. The Command window can be used to send immediate Mint commands to the MicroFlex.

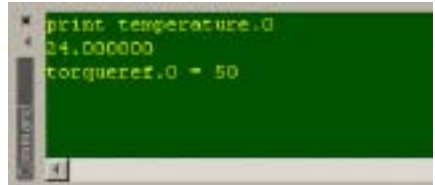

```

print temperature.0
34.000000
torqueref.0 = 50
  
```

- **Scope Tool**  
 Displays the capture screen. This screen is also shown when the Fine-tuning tool is selected.

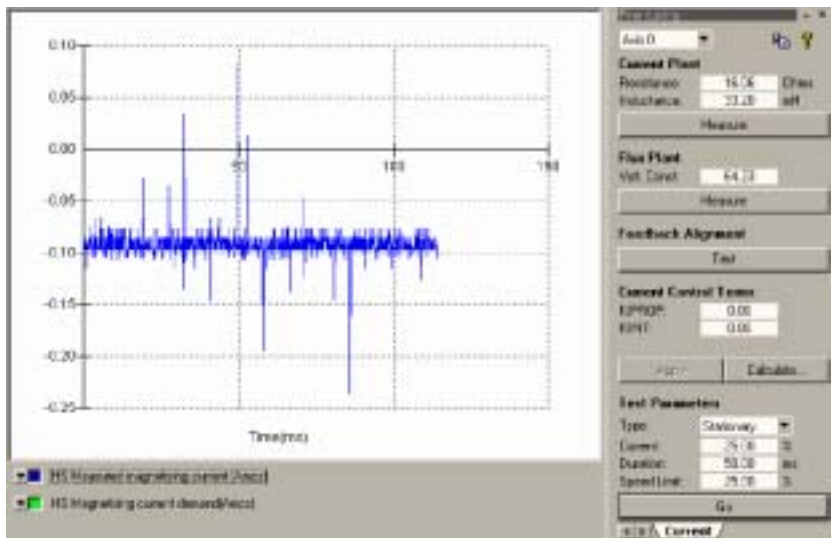

- **Spy window**  
 Allows you to monitor all the important parameters for the axis.

Remember, for help on each tool just press F1 to display the help file, then navigate to the WorkBench v5 book. Inside this is the Toolbox book.





## 7.1 Introduction

This section explains common problems that may be encountered, together with possible solutions.

### 7.1.1 Problem diagnosis

If you have followed all the instructions in this manual in sequence, you should have few problems installing the MicroFlex. If you do have a problem, read this section first and check the help file in WorkBench v5. If you cannot solve the problem or the problem persists, the SupportMe feature can be used.

### 7.1.2 SupportMe feature

The SupportMe feature is available from the Help menu or by clicking the  button on the motion toolbar. SupportMe can be used to gather information which can then be e-mailed, saved as a text file, or copied to another application. The PC must have e-mail facilities to use the e-mail feature. If you prefer to contact Baldor technical support by telephone or fax, contact details are provided at the rear of this manual. Please have the following information ready:

- The serial number of your MicroFlex.
- Use the Help, SupportMe menu item in WorkBench v5 to view details about your system.
- The catalog and specification numbers of the motor that you are using.
- Give a clear description of what you are trying to do, for example trying to establish communications with WorkBench v5 or trying to perform fine-tuning.
- Give a clear description of the symptoms that you can observe, for example the Status LED, error messages displayed in WorkBench v5, or the current value of the Mint error keywords AXI SERR0R and DRI VEERROR.
- The type of motion generated in the motor shaft.
- Give a list of any parameters that you have setup, for example the motor data you entered/selected in the Commissioning Wizard, the gain settings generated during the tuning process and any gain settings you have entered yourself.







### 7.1.3 Power-cycling the MicroFlex

The term "Power-cycle the MicroFlex" is used in the Troubleshooting sections. Remove the 24V supply, wait for the MicroFlex to power down completely (the Status LED will turn off), then re-apply the 24V supply.

## 7.2 Status LED

The Status LED indicates general MicroFlex status information.



	<p>Solid green: Drive enabled (normal operation).</p>																										
	<p>Flashing green: Firmware download in progress.</p>																										
	<p>Solid red: Drive disabled, but no errors are latched.</p>																										
	<p>Flashing red: Powerbase fault or error(s) present. The number of flashes indicates which error has occurred. For example, to display error 3 (overcurrent trip), the LED flashes 3 times at 0.1 second intervals, followed by a 0.5 second pause. The sequence is repeated continuously.</p> <table border="1" data-bbox="263 590 1002 997"> <thead> <tr> <th><u>Error code</u> (no. of flashes)</th> <th><u>Meaning</u></th> </tr> </thead> <tbody> <tr> <td>1 .....</td> <td>DC bus overvoltage trip.</td> </tr> <tr> <td>2 .....</td> <td>IPM (integrated power module) trip.</td> </tr> <tr> <td>3 .....</td> <td>Overcurrent trip.</td> </tr> <tr> <td>4 .....</td> <td>Overspeed trip.</td> </tr> <tr> <td>5 .....</td> <td>Feedback trip.</td> </tr> <tr> <td>6 .....</td> <td>Motor overload (I<sup>2</sup>t) trip.</td> </tr> <tr> <td>7 .....</td> <td>Overtemperature trip.</td> </tr> <tr> <td>8 .....</td> <td>Drive overload (I<sub>t</sub>) trip.</td> </tr> <tr> <td>9 .....</td> <td>Following error trip.</td> </tr> <tr> <td>10 .....</td> <td>Error input triggered.</td> </tr> <tr> <td>11 .....</td> <td>Phase search error.</td> </tr> <tr> <td>12 .....</td> <td>All other errors, including: Internal supply error, encoder supply error, parameter restore failure, power base not recognized.</td> </tr> </tbody> </table> <p>If multiple errors occur at the same time, the lowest numbered error code will be flashed. For example, a MicroFlex which has tripped on both feedback error (code 5) and over-current error (code 3) will flash error code 3. If the drive is already displaying an error code when a new error with a lower code occurs, the drive will start flashing the new code. Note that undervoltage trip does not appear in the table because it is already indicated by the green/red flashing state. If an undervoltage trip occurs in conjunction with another error, the drive will flash the code of the additional error.</p> <p>Further details about error codes can be found in the WorkBench v5 help file. Press F1 and locate the DRI VEERROR and AXI SERROR keywords, or the <i>Error Handling</i> book.</p>	<u>Error code</u> (no. of flashes)	<u>Meaning</u>	1 .....	DC bus overvoltage trip.	2 .....	IPM (integrated power module) trip.	3 .....	Overcurrent trip.	4 .....	Overspeed trip.	5 .....	Feedback trip.	6 .....	Motor overload (I <sup>2</sup> t) trip.	7 .....	Overtemperature trip.	8 .....	Drive overload (I <sub>t</sub> ) trip.	9 .....	Following error trip.	10 .....	Error input triggered.	11 .....	Phase search error.	12 .....	All other errors, including: Internal supply error, encoder supply error, parameter restore failure, power base not recognized.
<u>Error code</u> (no. of flashes)	<u>Meaning</u>																										
1 .....	DC bus overvoltage trip.																										
2 .....	IPM (integrated power module) trip.																										
3 .....	Overcurrent trip.																										
4 .....	Overspeed trip.																										
5 .....	Feedback trip.																										
6 .....	Motor overload (I <sup>2</sup> t) trip.																										
7 .....	Overtemperature trip.																										
8 .....	Drive overload (I <sub>t</sub> ) trip.																										
9 .....	Following error trip.																										
10 .....	Error input triggered.																										
11 .....	Phase search error.																										
12 .....	All other errors, including: Internal supply error, encoder supply error, parameter restore failure, power base not recognized.																										
  	<p>Alternate red/green flashing: Undervoltage warning (no AC power), but no errors are latched.</p> <p>The DC-bus voltage has dropped below the powerbase undervoltage level (see DRI VEBUSUNDERVOLTS). This error will only be generated if the drive is in the enabled state. Check the AC power is connected.</p>																										

## 7.2.1 Communication

Problem	Check
Status LED is off	Check that the 24VDC control circuit supply is connected correctly to connector X2 and is switched on.
WorkBench v5 fails to detect the MicroFlex - it detects "No controller found. Communication fault on COMx".	<p>Ensure that the MicroFlex is powered and the Status LED is illuminated (see section 7.2).</p> <p>Check that the serial cable is connected between the PC's COM port and connector X6 on the MicroFlex.</p> <p>Check which PC COM port is being used, or use the "Scan all serial ports" option to locate the MicroFlex.</p> <p>Check the wiring of the serial cable or try an alternate cable.</p> <p>On the PC, try an alternative COM port.</p> <p>Confirm that a mouse driver or other serial device is not conflicting (using the same COM port) as WorkBench v5.</p> <p>Does the MicroFlex have firmware in it? If you tried to download new firmware and the download failed, the controller may not have firmware.</p> <p>Check that the selected baud rate is supported by the PC and MicroFlex.</p> <p>If the "Only scan COMx" option is selected in WorkBench v5, check that the correct COM port is selected.</p> <p>If the "Search up to Nodexx" option is selected in WorkBench v5, check that the MicroFlex node number is not higher than this value, or search up to a greater node value.</p> <p>Do you have multiple nodes on the bus? If so, they must all be set to the same baud rate. WorkBench v5 scans through all the node ID's at different baud rates. When it finds a node, it will only continue to scan for other nodes at the same baud rate.</p>

## 7.2.2 Power on

Problem	Check
The Status LED is flashing.	<p>The MicroFlex has detected a motion error. Click the Error button on the motion toolbar to view a description of the error. Alternatively, type these commands in the Command window:</p> <pre>PRINT AXI SERROR PRINT DRI VEERROR</pre> <p>Click the <b>Clear Errors</b> button on the motion toolbar.</p>

## 7.2.3 Tuning

Problem	Check
Cannot enable the MicroFlex because AXI SERROR has bit 13 set	Check the drive enable input on connector X3 pins 6 and 7 is connected and powered correctly.
When the MicroFlex is enabled the motor is unstable	Check that the current loop has been tuned. Check that the current loop was tuned with the correct motor data. If the motor is still unstable try reducing the Speed Proportional gain (KVPROP) and Speed Integral gain (KVI NT) on the Speed tab of the Fine-tuning window.

## 8.1 Introduction

This section provides technical specifications for the MicroFlex.

### 8.1.1 AC input power and DC bus voltage (X1)

<i>All models</i>	Unit	AC input					
		1Φ			3Φ		
<b>Nominal input voltage</b>	VAC	115 or 230					
Minimum input voltage		105*					
Maximum input voltage		250					
<b>Nominal DC-bus voltage</b>	VDC	305			321		
<b>Nominal input current</b> @ maximum rated output current	A	<b>3A</b>	<b>6A</b>	<b>9A</b>	<b>3A</b>	<b>6A</b>	<b>9A</b>
		7.5	15	22	4	8	12

\* The MicroFlex will operate at lower input voltages, although the drive will trip if the DC-bus voltage falls below 50V or 60% of the no-load voltage, whichever occurs first.

#### 8.1.1.1 Effect of AC power supply voltage on DC-bus voltage

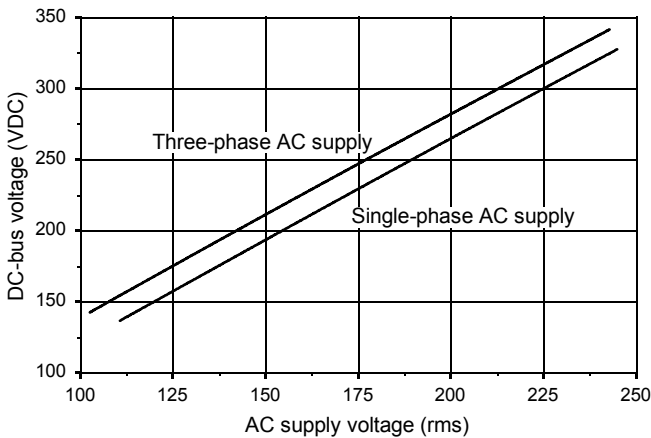

**8.1.1.2 Effect of AC power supply voltage on DC-bus ripple**

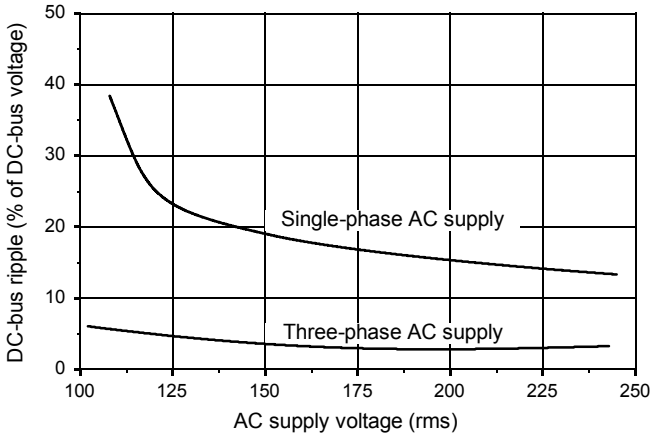

**8.1.1.3 Effect of output current on DC-bus ripple voltage**

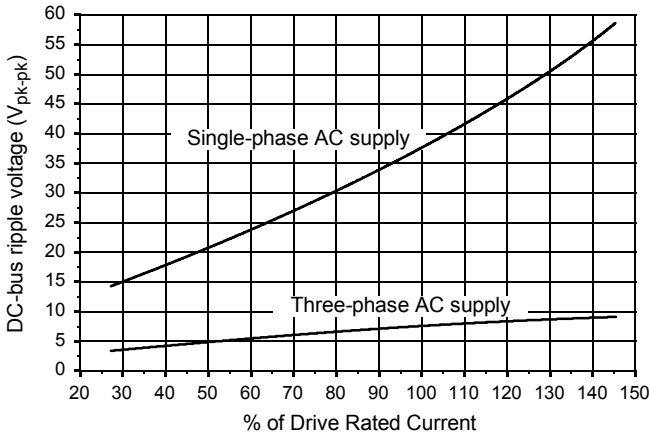

### 8.1.2 24VDC control circuit supply input (X2)

	Unit	3A	6A	9A
<b>Nominal input voltage</b>	VDC	24		
Minimum input voltage		20		
Maximum input voltage		30		
<b>Maximum ripple</b>	%	±10		
<b>Maximum continuous current @24VDC</b>	A	0.6		
<b>Power on surge current (typical) @24VDC, 100ms</b>	A	4		

### 8.1.3 Motor output power (X1)

	Unit	3A	6A	9A
<b>Nominal phase current</b>	$A_{RMS}$	3	6	9
<b>Peak phase current</b> for 0.5s	$A_{RMS}$	6	12	18
<b>Nominal output</b> @ 230V, 3Φ	VA	1195	2390	3585
<b>Output voltage range (line-line)</b> @VDC-bus=320V	$V_{RMS}$	0 - 230		
<b>Output frequency</b>	Hz	0 - 2000		
<b>Output dv/dt</b> at drive, phase-phase at drive, phase-ground at motor (using 20m cable), phase-phase at motor (using 20m cable), phase-ground	$kV/\mu s$	2 1.1 1.9 1.8		
<b>Nominal switching frequency</b>	kHz	8.0		
<b>Minimum motor inductance (per winding)</b>	mH	1		
<b>Efficiency</b>	%	>95		

### 8.1.4 Regeneration (X1)

	Unit	3A	6A	9A
<b>Nominal switching threshold (typical)</b>	VDC	on: 388, off: 376		
<b>Nominal power</b> (10% power cycle, R=57Ω)	kW	0.25		
<b>Peak power</b> (10% power cycle, R=57Ω)	kW	2.7		
<b>Maximum regeneration switching current</b>	$A_{PK}$	10		
<b>Minimum load resistance</b>	Ω	39		
<b>Maximum load inductance</b>	μH	100		

### 8.1.5 Analog input (X3)

	Unit	All models
Type		Differential
Common mode voltage range	VDC	±10
Common mode rejection	dB	>40
Input impedance	kΩ	>30
Input ADC resolution	bits	12
Equivalent resolution	mV	±4.9
Sampling interval	μs	125

### 8.1.6 Digital inputs - drive enable and general purpose (X3)

	Unit	All models
Type		Opto-isolated inputs
Input voltage	VDC	
Nominal		24
Minimum		12
Maximum		30
Input current (@ Vin=24V)	mA	6.7
Sampling interval	ms	0.5
Maximum pulse input frequency	MHz	1
Minimum pulse width	μs	5

### 8.1.7 Step and Direction inputs (X3)

	Unit	All models
Type		Non-isolated DC inputs
Input voltage	VDC	5
Input current (maximum, per input)	μA	20
Maximum step input frequency	MHz	1
Minimum pulse width	ns	250

### 8.1.8 Drive status output (X3)

	Unit	All models
User supply (maximum)	V	30
Output current (max. continuous)	mA	100
Fuse Approximate trip current Reset time	mA s	200 <20
Update interval	ms	0.5

### 8.1.9 Incremental encoder feedback option (X8)

	Unit	All models
Encoder input		A/B Differential, Z index
Maximum input frequency (quadrature)	MHz	8
Hall inputs		Single ended, 5V logic
Output power supply to encoder		5V, 200mA max.
Maximum recommended cable length		30.5m (100ft)

### 8.1.10 SSI encoder feedback option (X8)

	Unit	All models
SSI encoder inputs		Differential Data and Clock
Operating mode (Baldor motors)		Single turn. Positioning resolution up to 262144 counts/rev (18-bit)
Output power supply to encoder		5V, 200mA max.
Maximum recommended cable length		30.5m (100ft)

### 8.1.11 Encoder output (simulated) (X7)

	Unit	All models
Signal		RS422
Resolution with encoder input on X8		Output is a copy of the input on X8.
with SSI encoder input on X8		Adjustable simulated output. See section 4.1.3.

### 8.1.12 Serial RS232/RS485 interface (X6)

	Unit	All models
Signal		RS232, non-isolated CTS/RTS or RS485, non-isolated (model dependent)
Bit rate	baud	9600, 19200, 38400, 57600 (default)

### 8.1.13 Environmental

All models	Unit	All models		
Operating temperature range*		°C		°F
		+0 +45 See sections 3.2.2 to 3.2.5	+32 +113 See sections 3.2.2 to 3.2.5	
Minimum Maximum Derate				
Storage temperature range*		-40 to +85		-40 to +185
Humidity (maximum)*	%	93		
Forced air cooling flow (vertical, from bottom to top)	m/s	3A	6A	9A
		None required	1	2.5
Maximum installation altitude (above m.s.l.)	m	1000 Derate 1.1% / 100m over 1000m		
	ft	3300 Derate 1.1% / 330ft over 3300ft		
Shock*		10G		
Vibration*		1G, 10-150Hz		
IP rating		IP00**		

\* MicroFlex complies with the following environmental test standards:

BS EN60068-2-1:1993 low temperature operational 0°C.  
 BS EN60068-2-2:1993 high temperature operational 45°C.  
 BS EN60068-2-1:1993 low temperature storage/transportation -40°C.  
 BS EN60068-2-2:1993 high temperature storage/transportation +85°C.  
 BS 2011:part2.1 Cb: 1990: 45°C 93%RH humidity/high temperature operational.  
 DIN IEC 68-2-6/29

\*\* MicroFlex does not comply with EN61800-5-1:2003 part 5.2.2.5.3 (Impact test). Provided the MicroFlex case has not been damaged, and the terminals on connector X1 are covered to comply with EN60529:1991 part 12.3.1 (finger test), MicroFlex complies with IP20.

## **A.1 Introduction**

This section describes accessories and options that you may need to use with your MicroFlex. Shielded (screened) cables provide EMI / RFI shielding and are required for compliance with CE regulations. All connectors and other components must be compatible with the shielded cable.

### A.1.1 Fan tray

The fan tray (Baldor part FAN001-024) provides sufficient cooling for the 3A, 6A or 9A MicroFlex. It requires 23 - 27.5VDC at 325mA, which may be sourced from the same filtered control circuit supply used for the MicroFlex.

**Fan tray**  
FAN001-024

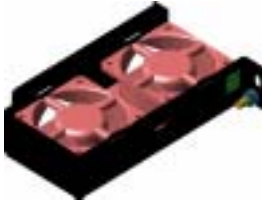

**Fan tray dimensions**

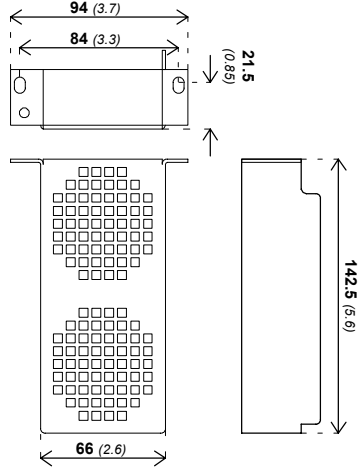

**Assembled MicroFlex and fan tray**



**Position of fan tray mounting holes relative to MicroFlex**

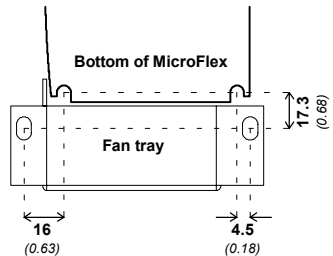

It is important that the fan tray is mounted in close proximity to the MicroFlex as shown above. Failure to do so will result in decreased cooling efficiency.

**Figure 38 - Fan tray**

## A.1.2 EMC filters

AC filters remove high frequency noise from the AC power supply, protecting the MicroFlex. These filters also prevent high frequency signals from being transmitted back onto the power lines and help meet EMC requirements. To select the correct filter, see sections 3.4.7 and 3.4.8.

### A.1.2.1 Catalog numbers

Baldor catalog number	Rated volts	Rated amps @ 40°C	Leakage current (mA)	Weight kg (lbs)
FI0014A00	250	3	0.4	0.27 (0.6)
FI0015A00	250	6	0.4	0.45 (0.99)
FI0015A01	250	10	0.4	0.73 (1.61)
FI0015A02	250	12	0.4	0.73 (1.61)
FI0018A00	480	7	33	0.5 (1.1)
FI0018A03	480	16	33	0.8 (1.76)
FI0028A00	250	22A	0.4 (estimated)	0.55 (1.21)

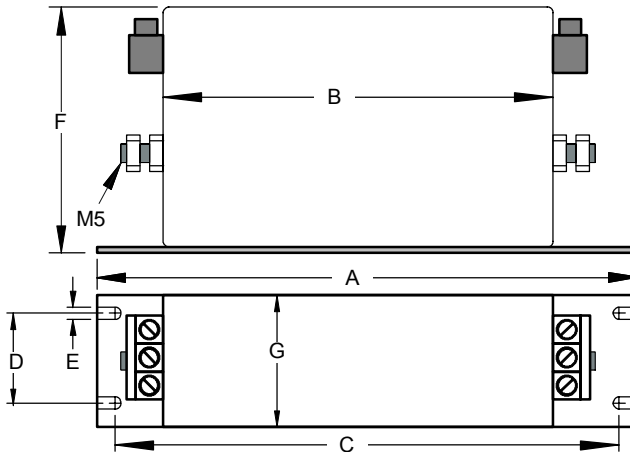

Dimension	Dimensions mm (inches)	
	FI0018A00 / FI0028A00	FI0018A03
A	190 (7.48)	250 (9.84)
B	160 (6.30)	220 (8.66)
C	180 (7.09)	235 (9.25)
D	20 (0.79)	25 (0.98)
E	4.5 (0.18)	5.4 (0.21)
F	71 (2.80)	70 (2.76)
G	40 (1.57)	45 (1.77)

Figure 39 - Filter dimensions, types FI0018A00, FI0018A03, FI0028A00

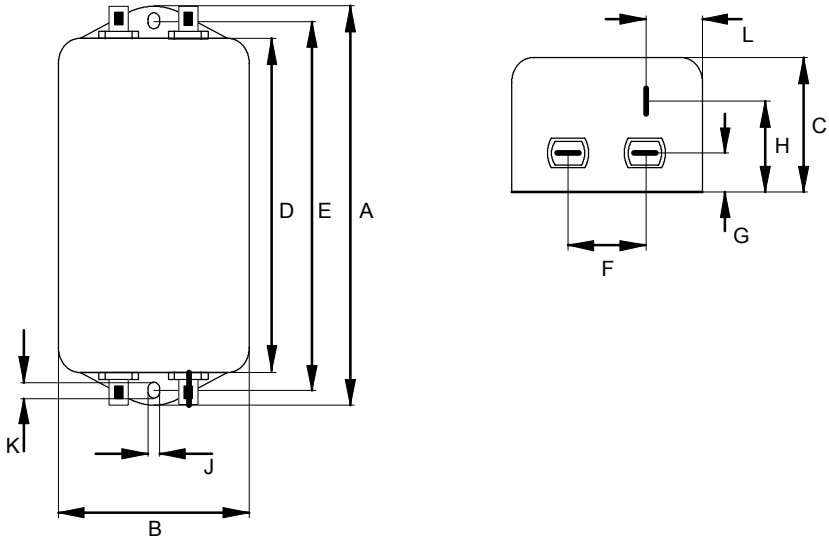

Dimension	Dimensions mm (inches)		
	FI0014A00	FI0015A00	FI0015A01 FI0015A02
A	85 (3.35)	113.5 (4.47)	156 (6.14)
B	54 (2.13)	57.5 (2.26)	
C	40 (1.57)	46.6 (1.83)	
D	65 (2.56)	94 (3.70)	130.5 (5.14)
E	75 (2.95)	103 (4.06)	143 (5.63)
F	27 (1.06)	25 (0.98)	
G	12 (0.47)	12.4 (0.49)	
H	29.5 (1.16)	32.4 (1.28)	
J	5.3 (0.21)	4.4 (0.17)	5.3 (0.21)
K	6.3 (0.25)	6 (0.24)	
L	13.5 (0.53)	15.5 (0.61)	

Figure 40 - Filter dimensions, types FI0014A00, FI0015A00, FI0015A01, FI0015A02

### A.1.3 Regeneration resistors

Depending on the application, MicroFlex might require an external regeneration resistor to be connected to pins R1 and R2 of connector X1. The regeneration resistor dissipates energy during braking to prevent an over-voltage error occurring.

Baldor part number RG56 is recommended (56 $\Omega$ , 44W). However, if the required dissipation is greater than this, Baldor part number RG39 may be used, rated at 100W.

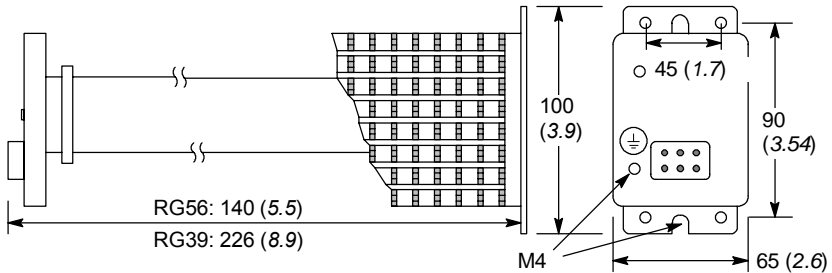

Dimensions: mm (*inches*)

**Figure 41 - Regeneration resistor dimensions**



**WARNING:** A regeneration resistor may generate enough heat to ignite combustible materials. To avoid fire hazard, keep all combustible materials and flammable vapors away from the brake resistors. Ensure that the resistor has clearance of at least 50mm (2 in) above and below and 26mm (1 in) left and right.

### A.1.4 Motor power cables

Cable rated current	Cable assembly description	Baldor catalog number	Length	
			ft	m
10 Amps	Power Cable Assembly: CE style threaded motor connector (motor end only)	CBL015SP-MHCE*	5	1.5
		CBL030SP-MHCE*	10	3.0
		CBL061SP-MHCE*	20	6.1
		CBL091SP-MHCE*	30	9.1
		CBL152SP-MHCE*	50	15.2
		CBL229SP-MHCE*	75	22.9
		CBL305SP-MHCE*	100	30.5
12 Amps	Power Cable Assembly: CE style threaded motor connector (motor end only)	CBL025SP-MHCE	8.2	2.5
		CBL050SP-MHCE	16.4	5.0
		CBL075SP-MHCE	24.6	7.5
		CBL100SP-MHCE	32.8	10
		CBL150SP-MHCE	49.2	15
		CBL200SP-MHCE	65.6	20
	Power Cable: no connectors	CBL029-501 / CBL050-501	3.3	1
		CBL029-502 / CBL050-502	164	50
		CBL029-503 / CBL050-503	328	100
		CBL029-504 / CBL050-504	656	200
	CBL029-505 / CBL050-505	984	300	

\* These cables are only available from the United States, since their length is specified primarily in imperial feet, not meters.

### A.1.5 Motor power cable part numbers

For easier installation, it is recommended that a color-coded Baldor motor power cable is used. A description of a Baldor rotary motor power cable catalog number is shown here, using the example number **CBL030SP-MHCE**:

	Meaning	Alternatives
<b>CBL</b>	The item is a cable	-
<b>030</b>	Indicates the length, in this example 3.0 meters	Various lengths are available
<b>SP</b>	The cable is a <b>S</b> ervo motor <b>P</b> ower cable	-
<b>M</b>	Current rating of 10A	<b>F</b> =20A; <b>E</b> =30A
<b>H</b>	8-pin connector	-
<b>CE</b>	Metric threaded CE connector	<b>M</b> =Metric threaded connector

Motor power cables are also available without connectors, in which case the final letters (**HCE** in the example above) are not used.

## A.1.6 SSI feedback cables

This table lists part numbers of Baldor feedback cables for use with the MicroFlex:

Cable assembly description	Baldor catalog number	Length	
		ft	m
Feedback Cable Assembly: standard-metric style threaded motor connector (motor end only)	CBL015SF-ALM*	5	1.5
	CBL030SF-ALM*	10	3.0
	CBL061SF-ALM*	20	6.1
	CBL091SF-ALM*	30	9.1
	CBL152SF-ALM*	50	15.2
	CBL229SF-ALM*	75	22.9
	CBL305SF-ALM*	100	30.5
Feedback Cable Assembly: CE style threaded motor connector and low density 15-pin D-type drive connector	CBL015SF-ALCE*	5	1.5
	CBL025SF-ALCE	8.2	2.5
	CBL030SF-ALCE*	10	3.0
	CBL050SF-ALCE	16.4	5
	CBL061SF-ALCE*	20	6.1
	CBL075SF-ALCE	24.6	7.5
	CBL091SF-ALCE*	30	9.1
	CBL100SF-ALCE	32.8	10
	CBL150SF-ALCE	49.2	15
	CBL152SF-ALCE*	50	15.2
	CBL200SF-ALCE	65.6	20
	CBL229SF-ALCE*	75	22.9
CBL305SF-ALCE*	100	30.5	
Feedback Cable: no connectors	CBL044-501	(Lengths as required)	

\* These cables are only available from the United States, since their length is specified primarily in imperial feet, not meters.

## A.1.7 Encoder / Hall feedback cables

Cable assembly description	Baldor catalog number	Length	
		ft	m
Feedback Cable Assembly: standard-metric style threaded connector (motor end only)	CBL015SF-KPM*	5	1.5
	CBL030SF-KPM*	10	3.0
	CBL061SF-KPM*	20	6.1
	CBL091SF-KPM*	30	9.1
	CBL152SF-KPM*	50	15.2
	CBL229SF-KPM*	75	22.9
	CBL305SF-KPM*	100	30.5
Feedback Cable Assembly: CE style threaded motor connector (motor end only)	CBL015SF-KPCE*	5	1.5
	CBL025SF-KPCE	8.2	2.5
	CBL030SF-KPCE*	10	3
	CBL050SF-KPCE	16.4	5
	CBL061SF-KPCE*	20	6.1
	CBL075SF-KPCE	24.6	7.5
	CBL091SF-KPCE*	30	9.1
	CBL100SF-KPCE	32.8	10
	CBL150SF-KPCE	49.2	15
	CBL152SF-KPCE*	50	15.2
	CBL200SF-KPCE	65.6	20
	CBL229SF-KPCE*	75	22.9
CBL305SF-KPCE*	100	30.5	
Feedback Cable Assembly: CE style threaded motor connector and low density 15-pin D-type drive connector	CBL025SF-KPCEA5	8.2	2.5
	CBL050SF-KPCEA5	16.4	5
	CBL075SF-KPCEA5	24.6	7.5
	CBL100SF-KPCEA5	32.8	10
	CBL150SF-KPCEA5	49.2	15
	CBL200SF-KPCEA5	65.6	20
Feedback Cable: no connectors	CBL043-501	(Lengths as required)	

\* These cables are only available from the United States, since their length is specified primarily in imperial feet, not meters.

## A.1.8 Feedback cable part numbers

A description of a Baldor feedback cable catalog number is shown here, using the example number **CBL030SF-ALCE**:

	Meaning	Alternatives
<b>CBL</b>	The item is a cable	-
<b>030</b>	Indicates the length, in this example 3.0 meters	Various lengths are available
<b>SF</b>	The cable is a <b>S</b> ervo motor <b>F</b> eedback cable	-
<b>A</b>	Resolver or SSI feedback cable	<b>K</b> =Encoder / Hall feedback cable
<b>L</b>	12-pin connector (for resolvers and SSI)	<b>P</b> =16-pin connector (for encoders)
<b>CE</b>	Metric threaded CE connector*	<b>M</b> =Metric threaded connector

**Note:** \* Feedback cables terminated with a CE connector (catalog numbers CBLxxxx-xx**CE**) have shields tied to the connector housing.

If you are not using a Baldor cable with your chosen feedback device, be sure to obtain a cable that is a shielded twisted pair 0.34mm<sup>2</sup> (22 AWG) wire minimum, with an overall shield. Ideally, the cable should not exceed 30.5m (100ft) in length. Maximum wire-to-wire or wire-to-shield capacitance is 50pF per 300mm (1ft) length, to a maximum of 5000pF for 30.5m (100ft).



## **B.1 Introduction**

The MicroFlex can be configured for three basic control modes:

- Current (Torque) control.
- Velocity (Speed) control.
- Step and Direction following/gearing.

The mode you require is selected in WorkBench v5 using the Commissioning Wizard. You can subsequently change between these control modes using the Tools, Control Mode menu item or by using the CONTROLMODE keyword in the Command window (see the Mint help file). Using the Parameter tool, you can define a mode for the drive to automatically select at start-up. The four control modes are described in the following sections.

### B.1.1 Current (Torque) control

Setting the control mode to Current Control configures the MicroFlex or MicroFlex as a torque amplifier, as shown in Figure 42. Here, a torque reference is obtained from a specified source:

- WorkBench v5
- A host using the ActiveX control
- Analog input

The source provides a signal that is fed into the Torque profiler.

The profiler generates a torque demand signal that smoothly changes between successive torque targets (reference values). This is achieved by specifying a rise time and fall time (see the WorkBench v5 Parameters tool). The torque demand signal is fed into the torque controller which determines the appropriate amount of current to apply to the windings of the motor. This demand current is compared with the actual winding current measured from sensors, and a suitable pulse width modulation (PWM) signal is generated. This PWM signal is fed to the power electronics in the drive.

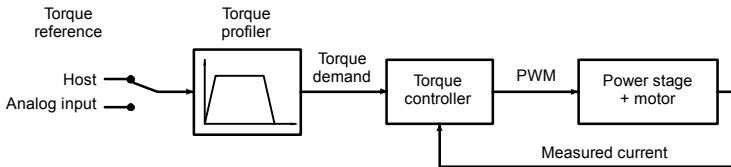

**Figure 42 - Control structure in Current (Torque) control mode**

The torque controller is a PI (Proportional Integral) controller. Gains are set using the Mint keywords `KI PROP` and `KI INT`. The torque demand is scaled into a current demand. This is compared with the measured current, obtained from the current sensors, and the error is fed into the PI control calculation. The resulting value forms the PWM signal that is fed through the power stage into the motor windings. The gain values `KI PROP` and `KI INT` must be tuned for a specific motor. This is performed automatically by the Commissioning Wizard.

The feedback device is used to determine motor position and speed. Motor speed can be filtered to reduce measurement noise if necessary. The time constant of this filter is specified using the keyword `KVTI ME`. By default the filter is turned off (`KVTI ME = 0`). Note that introducing a filter on measured speed tends to reduce the stability of the speed controller. This can make the tuning of the speed controller gains difficult if large values of `KVTI ME` are used.

## B.1.2 Velocity (Speed) control

Setting the control mode to Velocity Control configures the MicroFlex as a speed amplifier, as shown in Figure 43. Here, a speed reference is obtained from a specified source:

- WorkBench v5
- A host using the ActiveX control
- Analog input

The source provides a signal that is fed into the Speed controller.

The profiler generates a speed demand signal that smoothly changes between successive speed targets (reference values). This is achieved by specifying acceleration and deceleration times (see the WorkBench v5 Parameters tool). The speed demand signal is fed into the speed controller and used, together with the speed measured from the feedback device, to generate a torque demand signal. If the speed controller is tuned correctly, the measured speed will accurately track the speed demand.

Finally, the torque demand signal is fed into a torque controller, which determines the appropriate amount of current to apply to the windings of the motor. This demand current is compared with the actual winding current measured from sensors, and a suitable pulse width modulation (PWM) signal is generated. This PWM signal is fed to the power electronics in the drive.

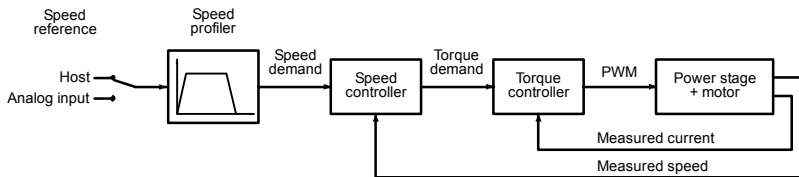

**Figure 43 - Control structure in Velocity control mode**

The speed controller is a PI (Proportional Integral) controller. Gains are set using the Mint keywords KVPROP, and KVIN T. The speed is compared with the measured speed and the error is fed into the PI control calculation. The speed control calculation is performed every 250 $\mu$ s, and the result forms the torque demand for the torque controller. As with the position controller, the gain values KVPROP and KVIN T must be tuned for each application. This can either be performed automatically within the Commissioning Wizard, or manually using the Fine-tuning tool of WorkBench v5.

### B.1.3 Position (Step and Direction) control

Setting the control mode to Position Control (Step and Direction) configures the MicroFlex as a positioning system, as shown in Figure 44, capable of following a position command signal.

The up down counter and gearing interpret the step and direction signals and use them to generate a position demand signal.

The position demand signal is fed into a position controller and used, together with the position measured from the feedback device, to generate a suitable speed demand signal. If the position controller is tuned correctly, the measured position will accurately track the position demand.

The speed demand signal from the position controller is fed into the speed controller and used, together with the speed measured from the feedback device, to generate a torque demand signal. If the speed controller is tuned correctly, the measured speed will accurately track the speed demand.

Finally, the torque demand signal is fed into a torque controller, which determines the appropriate amount of current to apply to the windings of the motor. This demand current is compared with the actual winding current measured from sensors, and a suitable pulse width modulation (PWM) signal is generated. This PWM signal is fed to the power electronics in the drive.

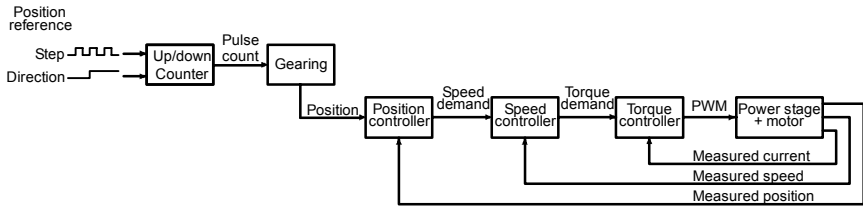

Figure 44 - Control structure in Position control (Step and Direction)

## C.1 Outline

This section provides general information regarding recommended methods of installation for CE compliance. It is not intended as an exhaustive guide to good practice and wiring techniques. It is assumed that the installer of the MicroFlex is sufficiently qualified to perform the task, and is aware of local regulations and requirements. Baldor products that meet the EMC directive requirements are indicated with a "CE" mark. A duly signed CE declaration of conformity is available from Baldor.



### C.1.1 EMC Conformity and CE marking

The information contained herein is for your guidance only and does not guarantee that the installation will meet the requirements of the council directive 89/336/EEC.

The purpose of the EEC directives is to state a minimum technical requirement common to all the member states within the European Union. In turn, these minimum technical requirements are intended to enhance the levels of safety both directly and indirectly.

Council directive 89/336/EEC relating to Electro Magnetic Compliance (EMC) indicates that it is the responsibility of the system integrator to ensure that the entire system complies with all relative directives at the time of installing into service.

Motors and controls are used as components of a system, per the EMC directive. Hence all components, installation of the components, interconnection between components, and shielding and grounding of the system as a whole determines EMC compliance.

The CE mark informs the purchaser that the equipment has been tested and complies with the appropriate standards. It rests upon the manufacturer or his authorized representative to ensure the item in question complies fully with all the relative directives in force at the time of installing into service, in the same way as the system integrator previously mentioned. Remember that it is the instructions of installation and the product that should comply with the directive.

### C.1.2 MicroFlex compliance

When installed as directed in this manual, MicroFlex units meet the emission limits for an 'industrial' environment, as defined by the EMC directives (EN61000-6-4: 2001). To meet the more stringent emission limits of the 'residential, commercial and light industrial' environment (EN61000-6-3: 2001), the MicroFlex must be mounted in a suitable metal cabinet incorporating 360° screened cable glands.

### C.1.3 Declaration of conformity



Baldor UK Limited  
Mint Motion Centre  
Hawkey Drive,  
Bristol Distribution Centre,  
Bristol, BS32 0BF  
United Kingdom  
Tel: (+44) 01454 850000

**Date: 23/07/03**    **EC Declaration of Conformity**    **Ref: DE00014-000**

This is to certify that MicroFlex single-axis Servo and Positioning Drives being one of:-

FMH2A03TR-EN23,    FMH2A06TR-EN23,    FMH2A09TR-EN23

built after the 30th June 2003, when used in accordance with the guidance given in the corresponding MicroFlex Installation Manual, MN1919, conforms with the protection requirements of Council Directive 89/336/EEC relating to Electromagnetic Compatibility, by the application of the following standards:-

Standard	Title	Comments
EN61800-3: 1996	<i>Adjustable speed electrical power drive systems Part 3: EMC Product standard including specific test methods.</i>	Emissions and immunity comply with the requirements for both the first (domestic) and second (industrial) environments

and in detail with the following basic standards:-

Standard	Title
EN 61000-6-3/4 : 2001 EN 61000-6-3/4 : 2001 EN 61000-4-3 : 1996 EN 61000-4-4 : 1995 EN 61000-4-2 : 1995 EN 61000-4-5 : 1995 + A1 : 2001 EN 61000-4-11 : 1994 EN 61000-3-2 : 2001	<i>Conducted Emissions (Light Industrial / Industrial) Radiated Emissions (Light Industrial / Industrial) Radiated Field Immunity EFT/Bursts ElectroStatic Discharge Surge Immunity Voltage Dips &amp; Interrupts Harmonic Current Emissions</i>

also conforms with the protection requirements of Council Directive 72/23/EEC relating to Low Voltage Equipment, by following the guidance found in the following standard:-

Standard	Title	Comments
EN 61800-5-1:2003	Adjustable speed electrical power drive systems. Safety requirements. Electrical, thermal and energy.	
EN 61800-2:1998	Adjustable speed electrical power drive systems. General requirements. Rating specifications for low voltage adjustable frequency a.c. power drive systems	
EN50178:1998	Electronic equipment for use in power installations	Over-voltage category II, protective earthing is required
EN60529: 1992	Specification for degrees of protection provided by enclosures (IP code)	

Signed:

Dr. Gerry Boast  
Engineering Manager

## C.1.4 Use of CE compliant components

The following points should be considered:

- **Using CE approved components will not guarantee a CE compliant system!**
- The components used in the drive, installation methods used, materials selected for interconnection of components are important.
- The installation methods, interconnection materials, shielding, filtering and earthing/grounding of the system as a whole will determine CE compliance.
- The responsibility of CE mark compliance rests entirely with the party who offers the end system for sale (such as an OEM or system integrator).

## C.1.5 EMC wiring technique

### **Cabinet**

Using a typical electroplated zinc coated enclosure, connected to earth/ground, means that all parts mounted on the back plane are connected to earth/ground and all outer shield (screen) connections can be connected to earth/ground. Within the cabinet there should be a spatial separation between power wiring (motor and AC power cables) and control wiring.

### **Shield (screen) connections**

All connections between components must use shielded cables. The cable shields must be connected to the enclosure. Use conductive clamps to ensure good earth/ground connection. With this technique, a good earth/ground shield can be achieved.

### **EMC filters**

The filter should be mounted next to the MicroFlex. The connections between the MicroFlex and the filter should use shielded (screened) cables. The cable shields should be connected to shield clamps at both ends. An exception to this is the analog command signal.

### **Earthing/grounding**

For safety reasons (VDE0160), all Baldor components must be connected to earth/ground with a separate wire. Earth/ground connections must be made from the central earth/ground (star point) to the regeneration resistor enclosure and from the central earth/ground (star point) to the power supply.

## C.1.6 EMC installation suggestions

To ensure electromagnetic compatibility (EMC), the following installation points should be considered to help reduce interference:

- Earthing/grounding of all system elements to a central earth/ground point (star point)
- Shielding of all cables and signal wires
- Filtering of power lines.

A proper enclosure should have the following characteristics:

- All metal conducting parts of the enclosure must be electrically connected to the back plane. These connections should be made with an earthing/grounding strap from each element to a central earthing/grounding point (star point). \*
  - Keep the power wiring (motor and power cable) and control wiring separated. If these wires must cross, be sure they cross at 90 degrees to minimize noise due to induction.
  - The shield connections of the signal and power cables should be connected to the shield rails or clamps. The shield rails or clamps should be conductive clamps fastened to the cabinet. \*\*
  - The cable to the regeneration resistor must be shielded. The shield must be connected to earth/ground at both ends.
  - The location of the AC filter has to be situated close to the drive so the AC power wires are as short as possible.
  - Wires inside the enclosure should be placed as close as possible to conducting metal, cabinet walls and plates. It is advised to terminate unused wires to chassis ground.\*
  - To reduce earth/ground current, use the largest suitable wire available for earth/ground connections.
- \* Earthing/grounding in general describes all metal parts which can be connected to a protective conductor, e.g. housing of cabinet, motor housing, etc. to a central earth/ground point (star point). This central earth/ground point (star point) is then connected to the main plant (or building) earth/ground.
- \*\* Or run as twisted pair at minimum.

### C.1.7 Wiring of shielded (screened) cables

Remove the outer insulation to expose the overall shield. Clamp should provide 360° contact with the cable.

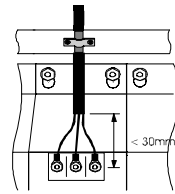
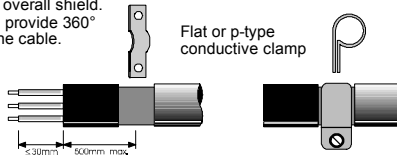

Figure 45 - Earthing/grounding cable shields

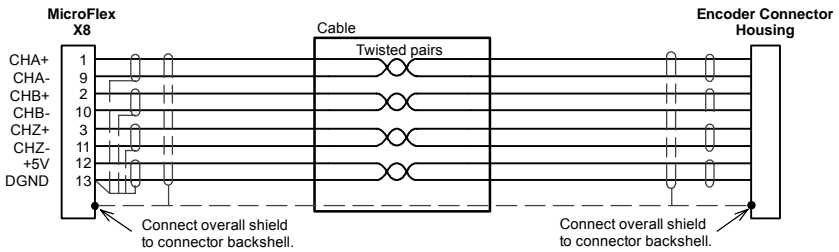

Figure 46 - Encoder signal cable grounding



**A**

Abbreviations. *See* Units and Abbreviations

Accessories, A-1

EMC filters, A-3

fan-tray, A-2

feedback cables, A-7, A-8

motor power cables, A-6

regeneration resistors, A-5

Analog I/O, 5-2

analog input - X3 (command), 5-2

**B**

Basic Installation, 3-1

**C**

Catalog number, identifying, 2-2

CE Guidelines, C-1

declaration of conformity, C-2

Command window, 6-11

Commissioning Wizard, 6-7

using, 6-7

Configuration, 6-8

Connections

*See also* Input / Output

feedback, 4-1

motor, 3-17

power, 3-10, 3-11

Connector, locations, 3-9

Control system, B-1

current (torque) control, B-2

position control (step & direction), B-4

velocity (speed) control, B-3

Cooling, 3-5, 3-6, 3-7, 3-8, A-2

overtemperature trips, 3-8

**D**

Demand input, 5-2

Derating, 3-6, 3-7, 3-8

Digital I/O, 5-4

general purpose digital input - X3, 5-7

status output - X3, 5-11

step & direction, 5-9

Dimensions, 3-4

Dynamic brake. *See* Regeneration resistor

**E**

Earthing (grounding)

leakage, 3-10

protection class, 3-10

protective earth (PE), 3-10

Encoder

cable, 4-3, A-8

feedback, 4-2

specification, 8-5

SSI. *See* Absolute encoder

without Halls, 4-4

Environmental

cooling, 3-3

location, 3-3–3-4

specification, 8-6

**F**

Features, 2-1

Feedback

cable, A-7–A-9

connections, 4-1

encoder, 4-2

encoder without Halls, 4-4

Halls-only feedback, 4-4

SSI, 4-6

Filters

24V control circuit supply, 3-16

AC power (EMC), 3-15, A-3

catalog numbers, A-3

Fuses, 3-14

---

## G

General Information, 1-1  
Grounding. See Earthing (grounding)

## H

Hardware requirements, 3-1  
Help file, 6-4

## I

Input / Output, 5-1  
  analog I/O, 5-2  
  analog input - X3, 5-2, 8-4  
  connection summary, 5-16  
  digital I/O, 5-4  
  digital input - X3, 8-4  
  drive status output - X3, 8-5  
  encoder output - X7, 4-8, 8-5  
  general purpose digital input - X3, 5-7  
  serial port - X6, 5-13, 8-6  
    multidrop using RS485/RS422 cable, 5-14  
  simulated encoder output, 4-8  
  status output - X3, 5-11  
  step & direction, 8-4

### Installation

See also Basic Installation  
Cooling, 3-5, 3-6, 3-7, 3-8  
dimensions, 3-4  
mechanical, 3-3  
mounting, 3-5

## L

LED indicator, 7-2  
Linear motor, cable configuration, 4-5

## M

Motor  
  circuit contactors, 3-18  
  connections, 3-17  
  power cable, 3-18–3-19, A-6  
Mounting, 3-5

## O

Operation, 6-1  
  connecting to the PC, 6-1  
  installing software, 6-1

  power on checks, 6-2  
  preliminary checks, 6-2  
  starting, 6-2

Operator panels, HMI operator panels, 5-15

### Overloads

  drive, 3-14  
  motor, 3-17  
  overtemperature trips, 3-8

## P

### Power

  24V control circuit supply, 3-16  
  connections, 3-10  
  discharge time, 3-12  
  disconnect and protection devices, 3-13  
  input conditioning, 3-12  
  input cycling, 3-12, 7-1  
  inrush, 3-12  
  sources, 3-1  
  supply filters, 3-15, A-3

Precautions, 1-2

Product Notice, 1-2

## R

Receiving and Inspection, 2-2

### Regeneration

  resistor, 3-20  
  specification, 8-3

### RS232

  specification, 8-6  
  X6, 5-13

### RS485

  multidrop using RS485/RS422 cable, 5-14  
  X6, 5-14

## S

Safety Notice, 1-2

Serial port, 5-13

  connecting serial Baldor HMI panels, 5-15

Simulated encoder output, 4-8

### Specifications, 8-1

  24V control supply, 8-3  
  AC input power and bus voltage, 8-1, 8-3  
  analog input - X3, 8-4  
  digital input - X3, 8-4

---

- drive status output - X3, 8-5
- encoder feedback - X8, 8-5
- encoder output - X7, 8-5
- environmental, 8-6
- regeneration, 8-3
- serial RS232 interface - X6, 8-6
- SSI encoder feedback - X8, 8-5
- step & direction inputs - X3, 8-4
- SSI, cable, 4-7, A-7
- SSI encoder, 4-6
  - specification, 8-5
- Status LED, 7-2
- Step & Direction, 5-9
  - specification, 8-4

## **T**

- Tools, 3-2
- Troubleshooting, 7-1
  - communication, 7-3

- power cycling, 7-1
- power on, 7-4
- problem diagnosis, 7-1
- Status LED, 7-2
- SupportMe, 7-1
- tuning, 7-4

## **U**

- Units and abbreviations, 2-3

## **W**

- Wires sizes, 3-14
- WorkBench v5, 6-3
  - Commissioning Wizard, 6-7
  - fine-tuning tool, 6-8
  - help file, 6-4
  - other tools and windows, 6-11
  - parameters tool, 6-10
  - starting, 6-5

---

If you have any suggestions for improvements to this manual, please let us know. Write your comments in the space provided below, remove this page from the manual and mail it to:

Manuals  
Baldor UK Ltd  
Mint Motion Centre  
6 Bristol Distribution Park  
Hawkley Drive  
Bristol  
BS32 0BF  
United Kingdom.

Alternatively, you can e-mail your comments to:

[manuals@baldor.co.uk](mailto:manuals@baldor.co.uk)

**Comment:**

*continued...*



---

*Thank you for taking the time to help us.*



# **BALDOR**

## **MOTORS, DRIVES & GENERATORS**

Baldor Electric Company  
P.O. Box 2400  
Ft. Smith, AR 72902-2400  
U.S.A.

Visit [www.supportme.net](http://www.supportme.net) for the latest documentation and software releases.

<b>Australia</b> Australian Baldor PTY Ltd Tel: +61 2 9674 5455 Fax: +61 2 9674 2495	<b>Mexico</b> Baldor de Mexico Tel: +52 477 761 2030 Fax: +52 477 761 2010
<b>Europe</b> Baldor ASR GmbH, Germany Tel: +49 (0) 89 905 080 Fax: +49 (0) 89 905 08491	<b>Singapore</b> Baldor Electric PTE Ltd Tel: +65 744 2572 Fax: +65 747 1708
<b>Europe (Southern)</b> Baldor ASR AG, Switzerland Tel: +41 52 647 4700 Fax: +41 52 659 2394	<b>United Kingdom</b> Baldor UK Ltd Tel: +44 1454 850000 Fax: +44 1454 859001
<b>Japan</b> Baldor Japan Corporation Tel: +81 45 412 4506 Fax: +81 45 412 4507	<b>U.S.A. (Headquarters)</b> Baldor Electric Company Tel: +1 479 646 4711 Fax: +1 479 648 5792
For additional office locations visit <a href="http://www.baldor.com">www.baldor.com</a>	